

**ATI**  
électronique

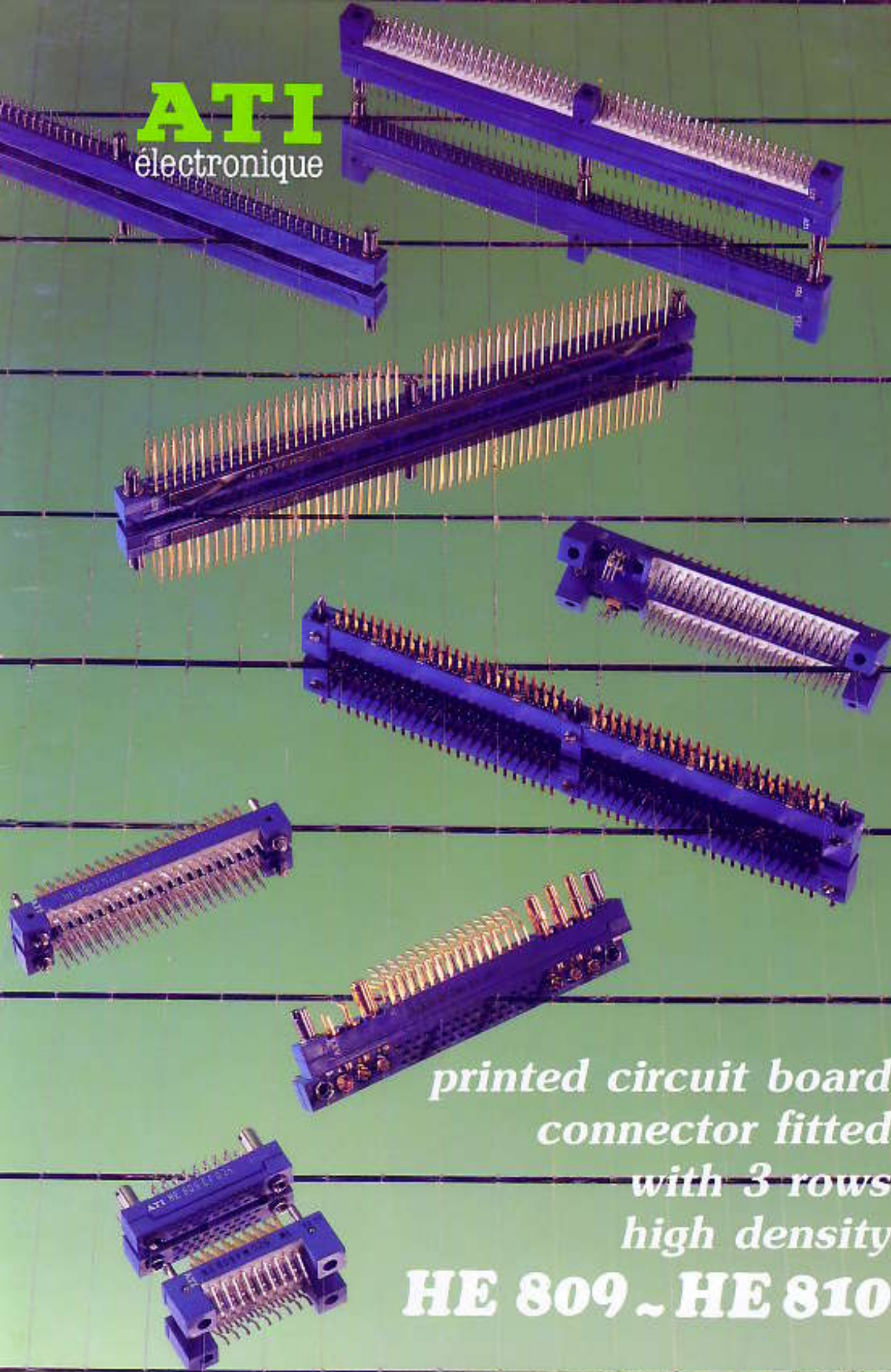

*printed circuit board  
connector fitted  
with 3 rows  
high density*  
**HE 809 ~ HE 810**

**SUMMARY**

## PAGES

---

Features - Material and finishes .....	2
Technical Characteristics .....	3
Installation conditions - Dimensions .....	4
Connector identification .....	5

---

**HE 809**

Mould sizes .....	6
Part number system .....	7
Right angle and SMT male .....	8
Mounting details right angle and SMT male .....	9
Solder, p.c. (straight) & wire wrapping female .....	10
Mounting details straight p.c. female .....	11
Straight p.c. female .....	12
Part number system straight p.c. male, right angle female and SMT .....	13
Straight p.c. male .....	14
Mounting details straight p.c. male .....	15
Right angle female and SMT .....	16
Mounting details right angle female and SMT .....	17

---

**HE 810**

Mould sizes .....	19 and 20
Part number system .....	21
Right angle and SMT male .....	22
Mounting details right angle male .....	23
Mounting details SMT male .....	25
Solder p.c. (straight) & wire wrapping female .....	26
Mounting details straight p.c. female .....	27
Straight p.c. female .....	28
Part number system straight p.c. male, right angle female and SMT .....	29
Straight p.c. male .....	30
Mounting details straight p.c. male .....	31
Right angle female and SMT .....	32
Mounting details right angle female and SMT .....	33
Operating instructions for coding adjustment .....	34
H.F. coaxial contacts .....	35 to 37
Interchangeability .....	38
Mounting details for coaxial contacts .....	39 and 40
High power contacts .....	41
Mounting details for printed circuit board connector with l.f. and high power contacts .....	42
Mounting details for extender card and removal tools for coaxial and high power contacts .....	43

---

# SERIES HE 809 and HE 810

---

## SPECIFICATIONS

High density p.c.b. connectors three rows, mainly dedicated to the aeronautic and military applications in accordance with :

- NF. UTE C 93424
  - CECC 75 101 001
- 

## FEATURES

The HE 809 series of connectors has three rows of L.F. contacts.

- Staggered pitch of 1.27 mm.
- Pitch between contact in the same row 2.54 mm.
- Pitch between rows 1.905 mating side and 2.54 mm termination side.

The HE 810 series offers the additional option of mixed layouts, 3, 6, 7 and 10 cavities capable of accepting coaxial, high power and optical inserts.

---

## MATERIAL AND FINISHES

### INSULATOR BODY

Moulding glass filled diallyl-phtalate.

### GUIDES

Stainless steel providing four functions : fixing, jacking, guiding, 6 positions coding (the centre guide is also polarised).

### FEMALE CONTACTS

Stamped, copper alloy.  
Contact type : running fork.  
Contact finish : gold over nickel.

### MALE CONTACTS

Stamped, copper alloy.  
Contact type : blade.  
Contact finish : gold over nickel.

---

**ISO 9002 - TQE.2 - QUALIFAS A - NATO Code : F 0318**

# SERIES HE 809 and HE 810

## TECHNICAL CHARACTERISTICS

### According to the NF/UTE C 93424

Working voltage (at sea level 1013 mbar)	: 250 Vrms, 50 Hz.
Proof voltage	: 1000 Vrms.
Nominal current per contact	: 3 A.
Contact resistance	: 0.012 Ohms max.
Dry insulation resistance	: $5 \cdot 10^3$ M Ohms min.
Separating force per contact	: 0.14 N min.
Environmental classification	: 434 : - 55 + 125°C.
Mechanical endurance	: 500 operations min.
Contact security on extraction	: 1,5 mm withdrawal
Random vibrations	: Tests request

## HE 810 COAXIAL CONTACTS

Reference specification	: NFC 93569 KMX 3 Series.
Environmental classification	: 434 : - 55 + 125°C.
Characteristic impedance	: 50 Ohms.
Operating frequency	: 1000 MHz.
Working peak voltage	: 250 V.
Reflection coefficient at 1000 MHz	: 1.3 max.
Connecting cables	: Flexible KX 21 A (NFC 93550). : Flexible KX 22 A (NFC 93550). : Flexible, other : see page 36. : Semi-rigid KS 1 (NFC 93551) Other coaxial, cables than those specified can be used : Please consult factory.

## HE 810 HIGH POWER CONTACTS

Characteristics	Conformity with NFC 93569 - KMX3	Special
Climatic range	434 : - 55° C + 125° C	434 : - 55° C + 125° C
Nominal current	10 A	20 A (25 A peak) under 30 Vdc
Usable cables	AWG 1,6 max. max. Ø insulator 2,8	AWG 12 to 16

# SERIES HE 809 and HE 810

## INSTALLATION CONDITIONS

The daughter board fitted with the male free connector must use card guides.

Alignment and polarisation of male free connector :

- 1 - On assembly it is essential that the T.P. error of the guide axis is not greater than 0.3 mm.
- 2 - There must be sufficient card guide clearance to enable the connector to be adjusted to its theoretical axis.

The drilling of p.c. holes for termination styles Y• & V• must conform to the specification requirements.

The diameter must be a minimum of 0.75 mm.

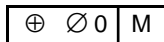

It is therefore advisable for this diameter to be marginally greater than 0.75 mm. in order to allow for board hole tolerances and facilitate easier insertion of the larger connector sizes.

In order to provide easier insertion of the contact termination into the p.c.b. the following tools can be supplied :

- For HE 809 : B24.
- For HE 810 : B24 + additional B28.

They are essential for right angle termination female connectors and are recommended for the larger sizes (right angle male and straight female).

## DIMENSIONS OF 2 MATED CONNECTORS

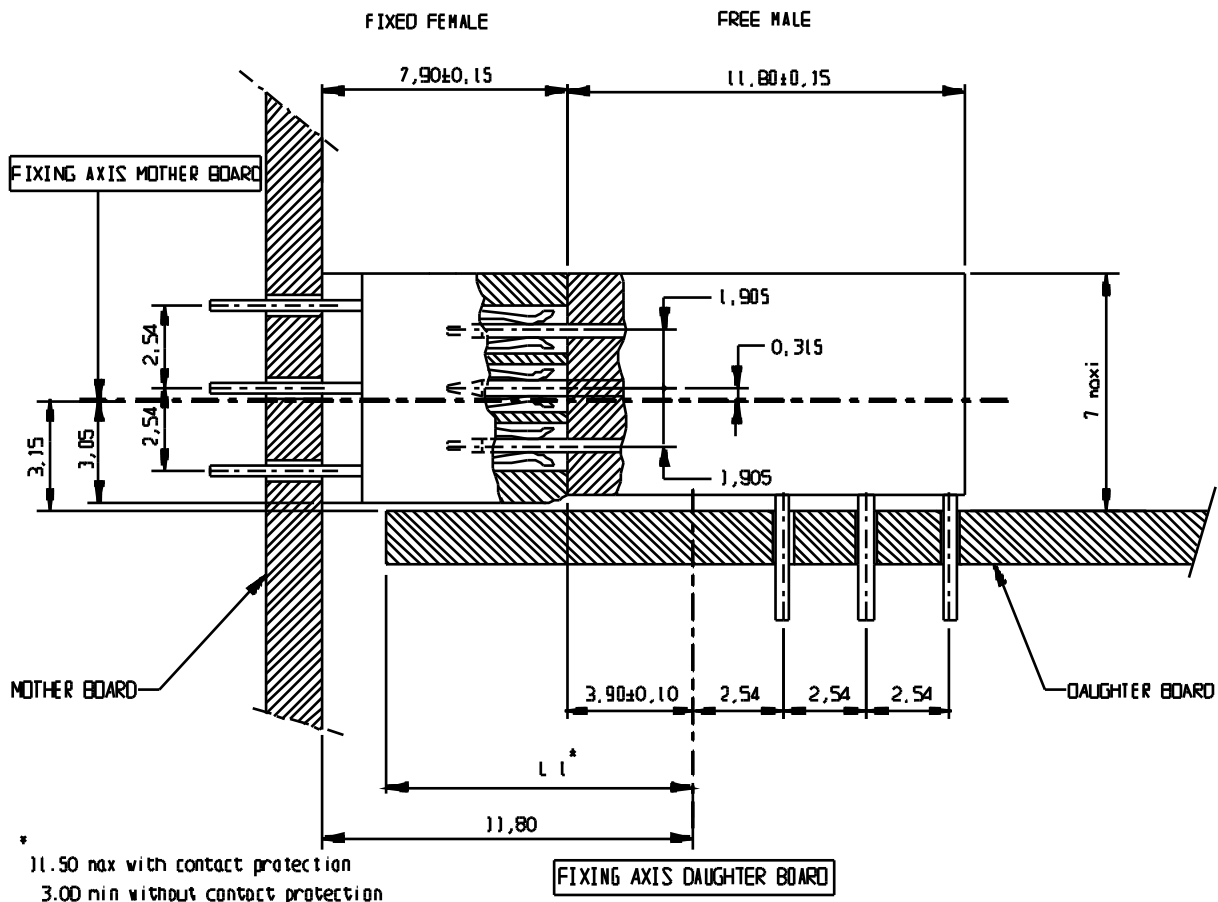

NOTE : See page 43 (dimensions for extender card).

# CONNECTOR IDENTIFICATION

## HE 809

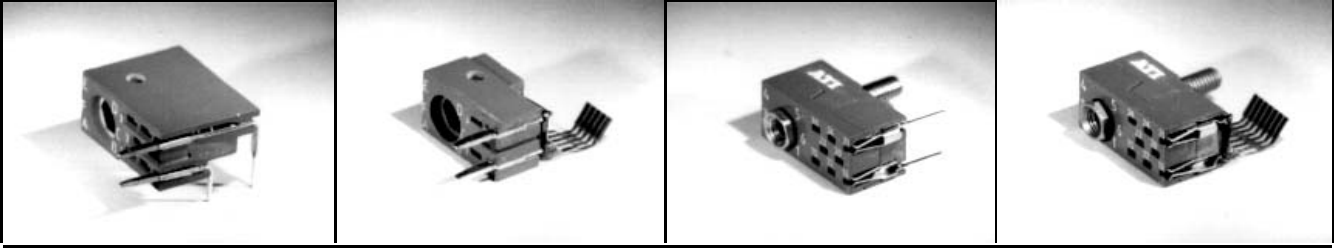

## CONNECTOR MARKING

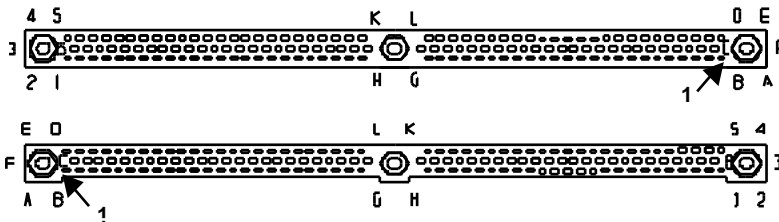

Marking of the "SOCKET" viewed on the mating side (n° 1 right down).

Marking of the "PLUG" viewed on the mating side (n° 1 left down).

### IDENTIFICATION

Connector identification may be partial and restricted to section.\*

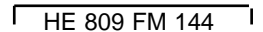

## HE 810

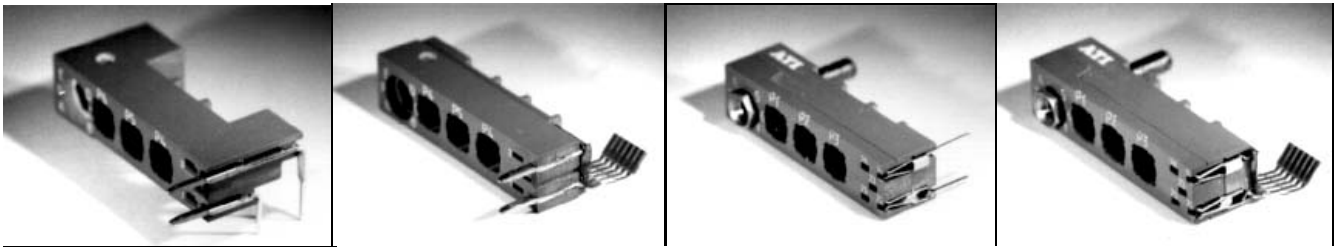

## CONNECTOR MARKING

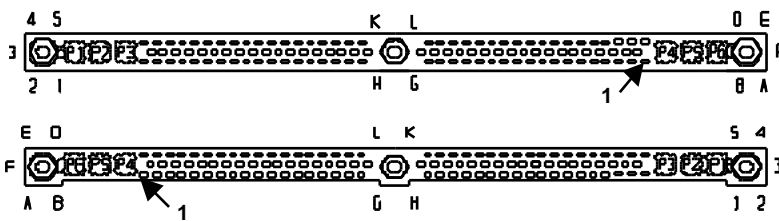

Marking of the "SOCKET" viewed on the mating face. Contacts are numbered, L.F. from the right, coaxial/power from the left.

Marking of the "PLUG" viewed on the mating face. Contacts are numbered, L.F. from the left, coaxial/power from the right.

### PARTICULAR CASE : MOULDING WITH CAVITIES FOR COAXIAL AND POWER CONTACTS JUST ON ONE SIDE

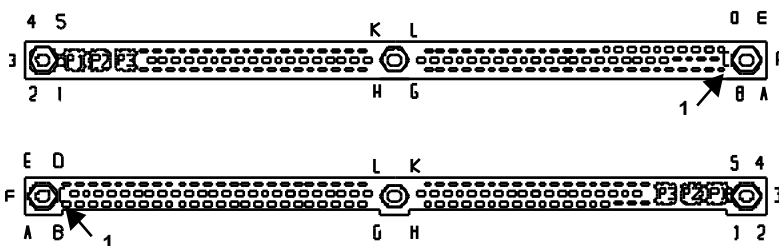

The connectors equipped with female contacts have a marking "SOCKET" only. Contacts are numbered, L.F. from the right, coaxial/power from the left.

The connectors equipped with male contacts have a marking "PLUG" only. Contacts are numbered, L.F. from the left, coaxial/power from the right.

### IDENTIFICATION

Connector identification may be partial and restricted to section.\*



\* See page 7.

# SERIES HE 809

## MOULD SIZES AND DIMENSIONS

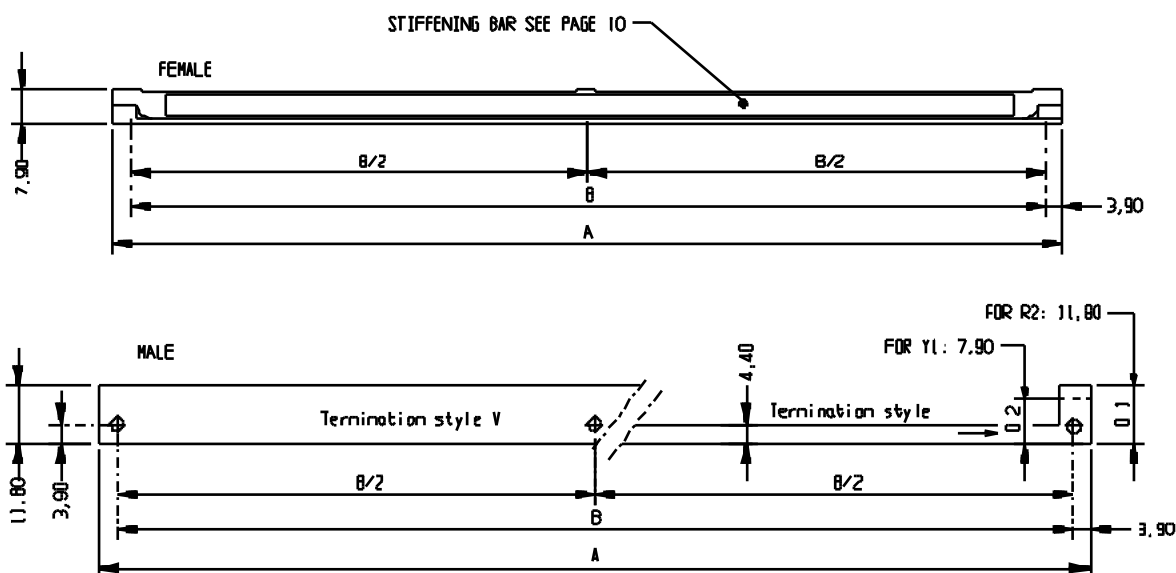
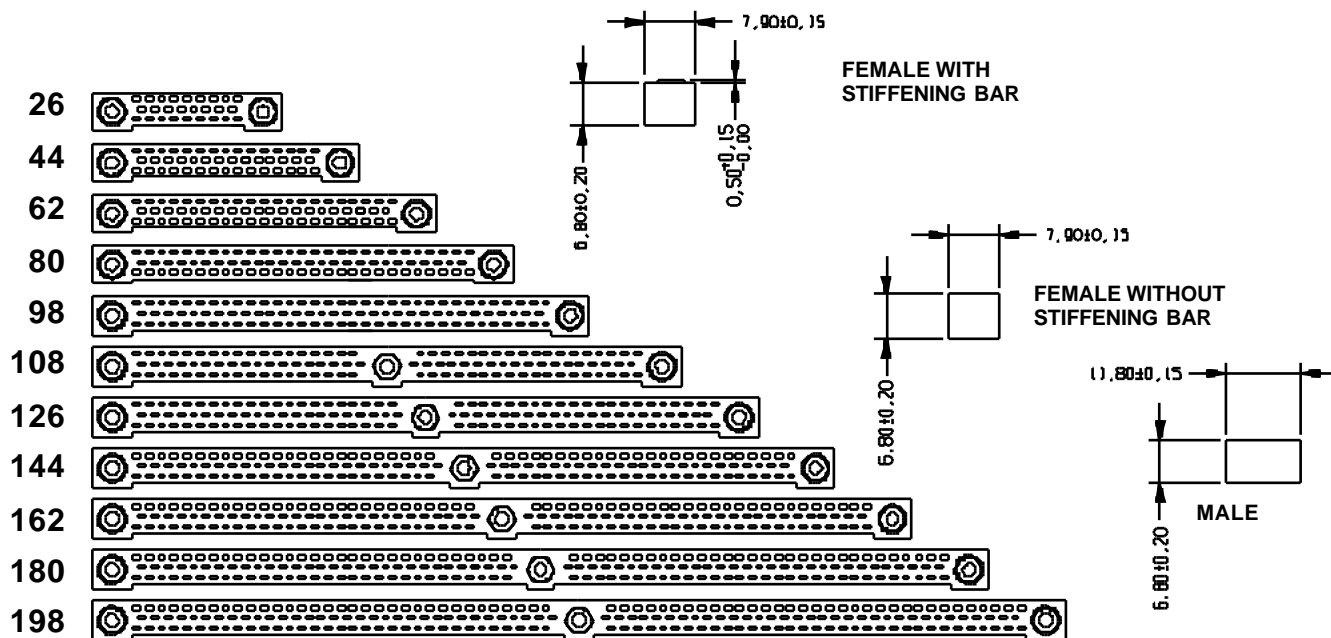
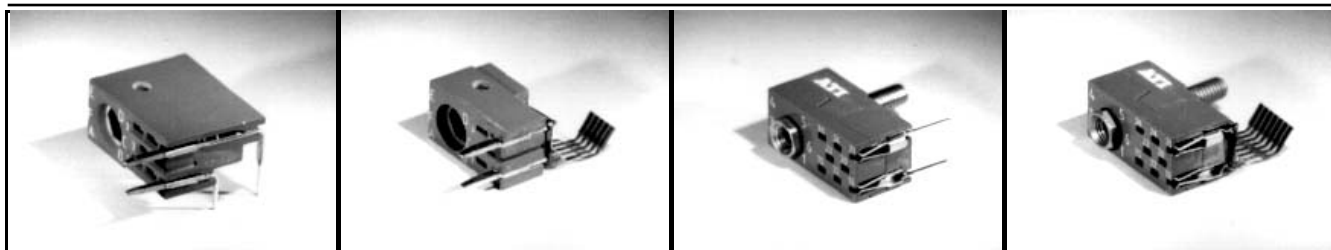

CONTACTS	26	44	62	80	98	108	126	144	162	180	198
A <sup>0</sup> -1	38.5	53.7	69	84.2	99.5	114.7	129.9	145.2	160.4	175.7	190.9
B	30.48	45.72	60.96	76.2	91.44	106.68	121.92	137.16	152.4	167.64	182.88

# SERIES HE 809

## PART NUMBER SYSTEM

<b>RIGHT ANGLE AND SMT MALE PLUG</b>	<b>HE 809 FM 144</b>	<b>A</b>	<b>V1</b>	<b>A</b>	<b>3</b>	<b>0.8</b>
<b>RIGHT ANGLE AND SMT MALE SOCKET</b>	<b>HE 809 EM 144</b>	<b>A</b>	<b>V1</b>	<b>A</b>	<b>3</b>	<b>0.8</b>

Number of contacts (sizes)  
026-044-062-080-098-108-126-144-162-180-198

Options : Without stiffening bar  
Description and conditions of use  
See page 8

Termination styles

V1, V2, R2

Guide styles

A, K, F, AB, L, AC, P

Termination finish

Tin alloy

3

**Contact area finish :**

Standard : 0.8 micron min. gold thickness (previously B)

0.8

Others \* : 1.27 micron min. gold thickness (previously C)

1.2

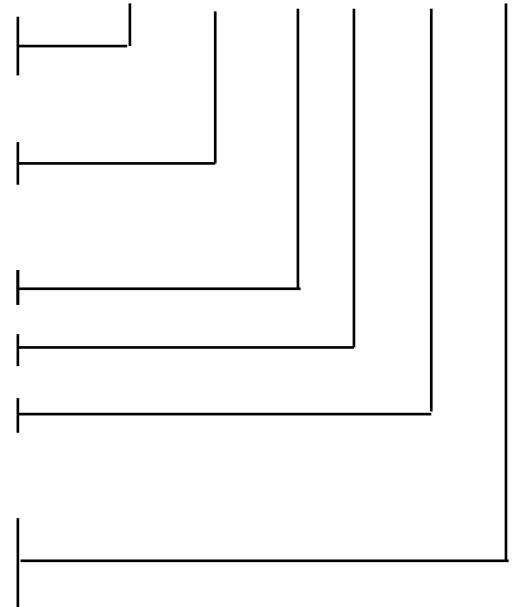

<b>STRAIGHT P.C. FEMALE SOCKET</b>	<b>HE 809 EF 098</b>	<b>A</b>	<b>Y3</b>	<b>B</b>	<b>3</b>	<b>0.8</b>
<b>STRAIGHT P.C. FEMALE PLUG</b>	<b>HE 809 FF 098</b>	<b>A</b>	<b>Y3</b>	<b>B</b>	<b>3</b>	<b>0.8</b>

Number of contacts (sizes)  
026-044-062-080-098-108-126-144-162-180-198

Options : Without stiffening bar  
Description and conditions of use With stiffening bar  
See page 10

Termination styles

Y1, Y2, Y3, Y4, Y6, K2, K3, C1

Guide styles

B, C, H, J, Q, S, T, W, X

Termination finish  
See page 10

Gold  
Tin alloy

2

3

**Contact area finish :**

Standard : 0.8 micron min. gold thickness (previously B)

0.8

Others \* : 1.27 micron min. gold thickness (previously C)

1.2

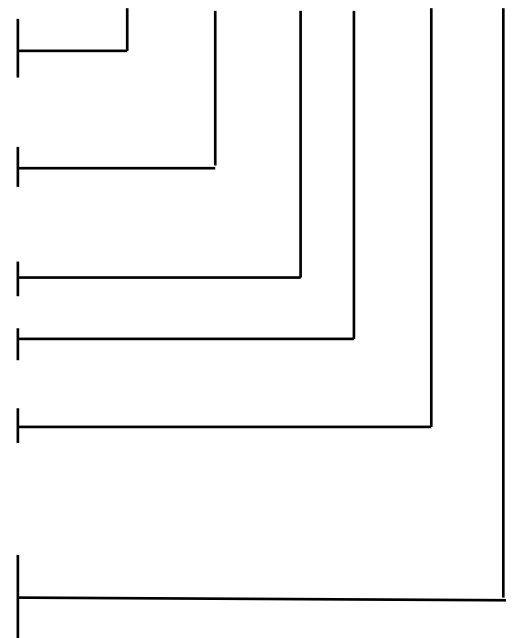

\* Other finishes can be supplied but a minimum contact quantity is required : Please consult factory.



# SERIES HE 809

## RIGHT ANGLE AND SMT MALE

### TERMINATIONS STYLES L.F.

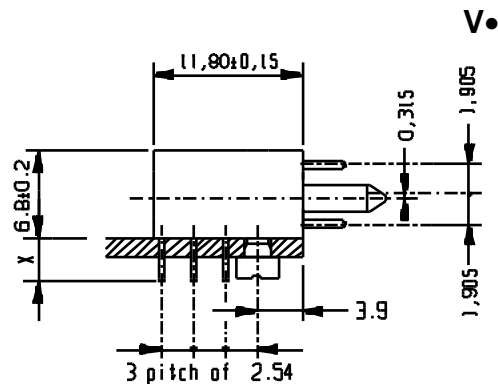

	X	
	min.	max.
<b>V1</b> : for use with 1.6 p.c.b.	2.6	3.2
<b>V2</b> : for use with 2.4 p.c.b.	3.4	4

Termination : Tin alloy.

### R2

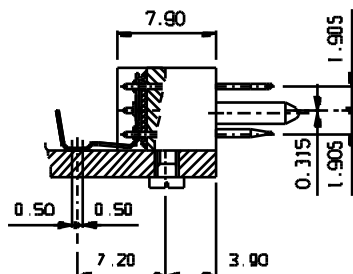

R2 : SMT flexible circuit connection

Termination : Tin alloy.

### OPTIONS

Stiffening bar	Standard termination
Without	Code A

### GUIDE STYLES

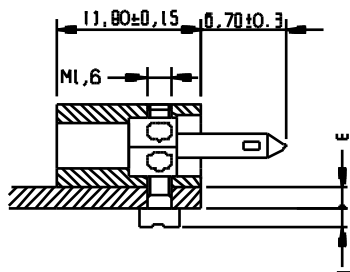

E : p.c.b. thickness 1.6 and 2.4  
E : p.c.b. thickness 2.4 and 3.2

**A**  
**K**

For moulds with 2 or 3 guides.  
For style V and R.  
Tightening torque : 0.07 to 0.09 Nm.  
All guides with 6 positions of coding.  
Mates with guide styles B, C, H, J, U.

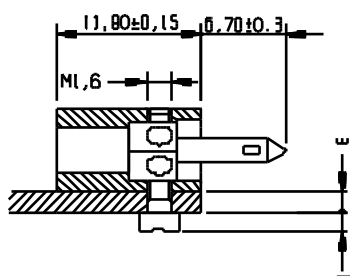

E : p.c.b. thickness 1.6 and 2.4  
E : p.c.b. thickness 2.4 and 3.2

**F**  
**AB**

For moulds with 3 guides only.  
For style V and R.  
Tightening torque : 0.07 to 0.09 Nm.  
Centre guide without coding.  
Mates with guide styles B, C, H, J, U.

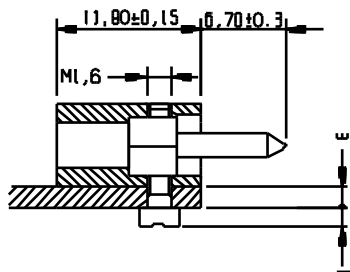

E : p.c.b. thickness 1.6 and 2.4  
E : p.c.b. thickness 2.4 and 3.2

**L**  
**AC**

For moulds with 2 or 3 guides.  
For extender card only.  
Tightening torque : 0.07 to 0.09 Nm.  
All guides without coding.  
Mates with guide styles B, C, H, J, U.

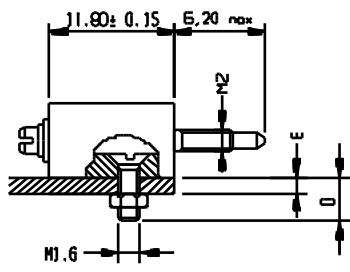

E : p.c.b. thickness 1.6 and 2.4  
D : 5

**P**

For moulds with 2 or 3 guides.  
For style V and R.  
Tightening torque mounting nut : 0.17 to 0.20 Nm.  
Guide 0.07 to 0.09 Nm.  
Jacking guide without coding.  
Centre guide without coding as with guide style L.  
Mates with guide style Q.

Other options : see Additional 97.

When used with a high vibration level, a fixative (Loctite or similar) is recommended to keep the screw tight.

# SERIES HE 809

## MOUNTING DETAILS RIGHT ANGLE AND SMT MALE

From 26 to 98 ways

2 GUIDES

Dimensions for contact style V•

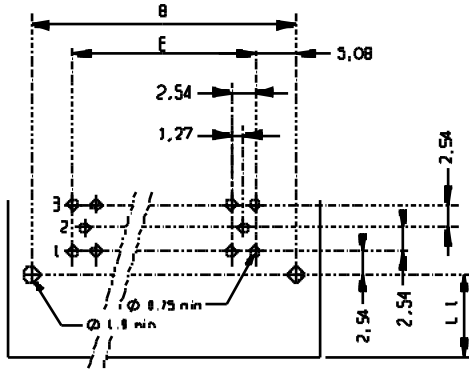

L1 :

Min. : 3

Max. : - When used with a straight p.c. female : 11.50 (see page 4).  
 - When used with a right angle female or an extender card : 9.50 (see page 43).

SIZES	026	044	062	080	098
E	20.32	35.56	50.8	66.04	81.28
B ± 0,2	30.48	45.72	60.96	76.2	91.44

NOTE :

The marking shown is for a "PLUG" connector.  
 For a "SOCKET" connector, the numbers 1, 2, 3 are located at the opposite end.

From 108 to 198 ways (144 for SMT)

3 GUIDES

Dimensions for contact style V•

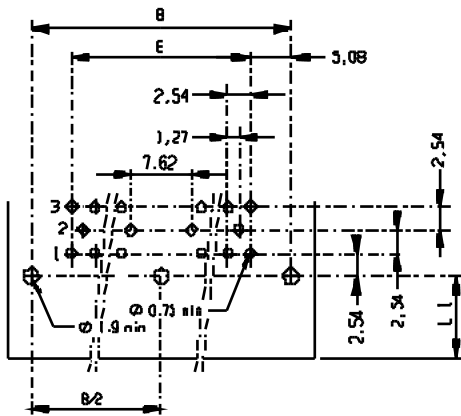

L1 :

Min. : 3

Max. : - When used with a straight p.c. female : 11.50 (see page 4).  
 - When used with a right angle female or an extender card : 9.50 (see page 43).

SIZES	108	126	144	162	180	198*
E	96.52	111.76	127	142.24	157.48	172.72
B ± 0,2	106.68	121.92	137.16	152.4	167.64	182.88

NOTE :

The marking shown is for a "PLUG" connector.  
 For a "SOCKET" connector, the numbers 1, 2, 3 are located at the opposite end.

P.c.b. layout for R2 termination (SMT), see Additional 97

# SERIES HE 809

## SOLDER, P.C. (STRAIGHT) & WIRE WRAPPING FEMALE

### TERMINATION STYLES L.F.

### STANDARD GUIDE STYLES

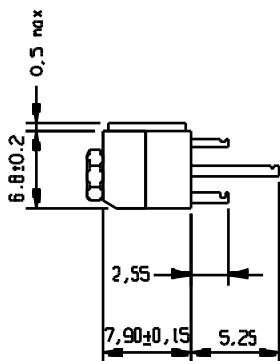

**C1**

Termination : Tin alloy.

C1 : Solder wire  $\varnothing$  0.6 max. (24 AWG).

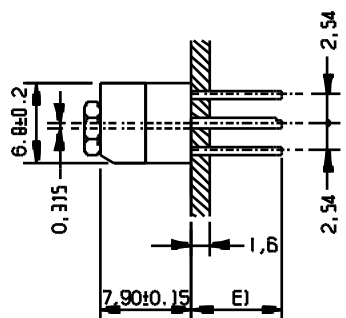

**Y0**

Termination : Tin alloy.

E1

	min.	max.
Y1 : for use with 1.6 p.c.b.	2.6	3.2
Y2 : for use with 2.4 p.c.b.	3.4	4
Y3 : for use with 3.2 p.c.b.	4.2	4.8
Y4 : for use with 4,5 p.c.b.	5.7	6.15
Y6 : for use with 8,5 p.c.b. Drilling diameter on p.c.b. 0.9 mm	9.7	10.15

SECTION



**K**

Termination : Gold

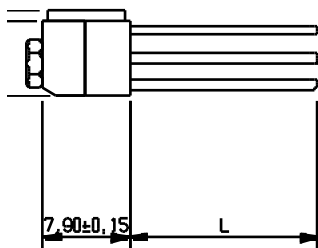

Wire wrapping terminations

K2 : 2 wraps L = 10.65

K3 : 3 wraps L = 14.60

### OPTIONS

Stiffening bar	Standard termination	Rear sealing
WITHOUT	Code A	Not available
WITH	Code B	

NOTE : The stiffening bar is standard with C and K styles for 80 ways and above.

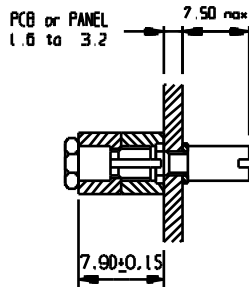

**B**

For moulds with 2 or 3 guides. Female with 6 positions of coding for termination styles C1, Y1, Y2, Y3 (K2, K3).  
Tightening torque : 0.20 to 0.25 Nm.  
Mates with guide styles A, K, F, AB, L, AC, G.  
(See guide S - page 12).

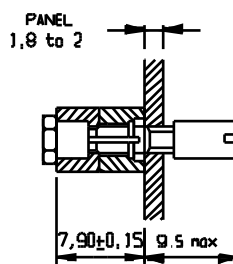

**C**

For moulds with 2 or 3 guides. Floating female with 6 positions of coding for termination styles C1, K2, K3.  
Tightening torque : 0.07 to 0.09 Nm.  
Mates with guide styles A, K, F, AB, L, AC, G.

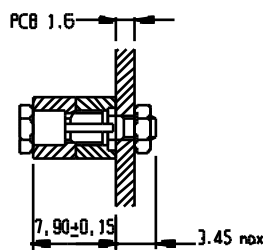

**H**

For moulds with 2 or 3 guides. Female with 6 positions of coding for termination style Y1.  
Tightening torque : 0.20 to 0.25 Nm.  
Mates with guide styles A, K, F, AB, L, AC, G.

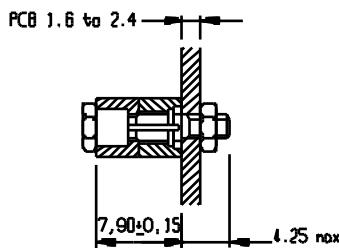

**J**

For moulds with 2 or 3 guides. Female with 6 positions of coding for termination styles Y1, Y2.  
Tightening torque : 0.20 to 0.25 Nm.  
Mates with guide styles A, K, F, AB, L, AC, G.  
P.c.b. thickness 3.2.  
(See guide S - page 12).

Other guide styles, see page 12 and Additional 97

For modification to the polarising - see page 34.

When used with a high vibration level, a fixative (Loctite or similar) is recommended to keep the screw tight.

# SERIES HE 809

## MOUNTING DETAILS STRAIGHT P.C. FEMALE

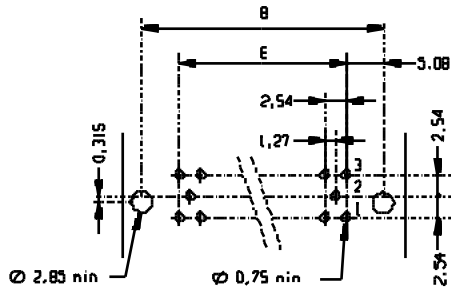

### From 26 to 98 ways

2 GUIDES

Dimensions for contact style Y•

Panel cut-out for termination styles C and K with guide styles B or C.

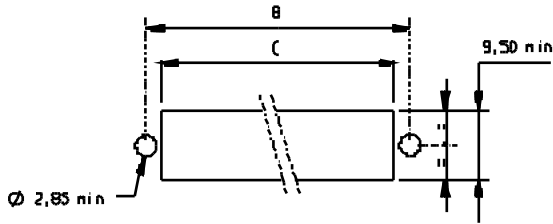

Contacts	026	044	062	080	098
E	20.32	35.56	50.8	66.04	81.28
B ± 0,2	30.48	45.72	60.96	76.2	91.44
C min.	25.9	41.1	56.4	71.6	86.9

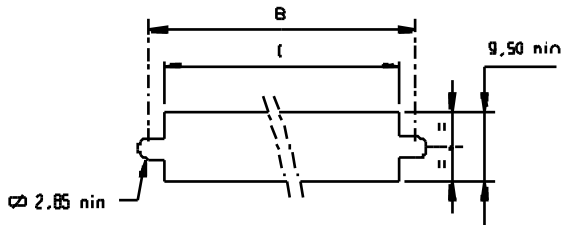

Alternative for float mounting.

**NOTE :**

The marking shown is for a "SOCKET" connector.  
For a "PLUG" connector, the numbers 1, 2, 3 are located at the opposite end.

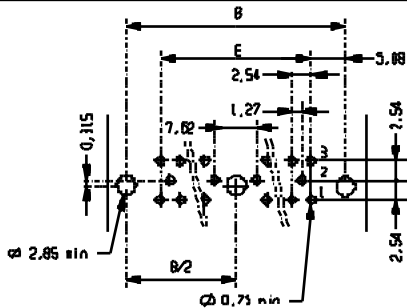

### From 108 to 198 ways

3 GUIDES

Dimensions for contact style Y•

**Note :** With guide style T.

- Drilling  $\varnothing 3 \pm 0.01$  instead of 2.85.

-  $\varnothing$  max. of the 2 holes p.c.b. pads located of the both sides of the central guide 1.4 max.

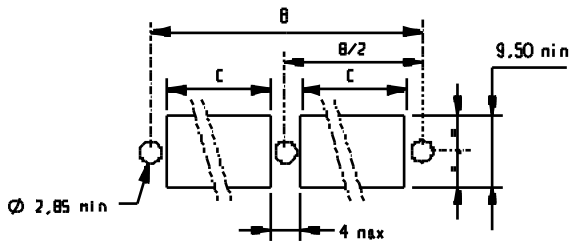

Panel cut-out for termination styles C and K , with guide styles B or C.

Contacts	108	126	144	162	180	198
E	96.52	111.76	127	142.24	157.48	172.72
B ± 0,2	106.68	121.92	137.16	152.4	167.64	182.88
C min.	48.35	55.95	63.6	71.2	78.80	86.45

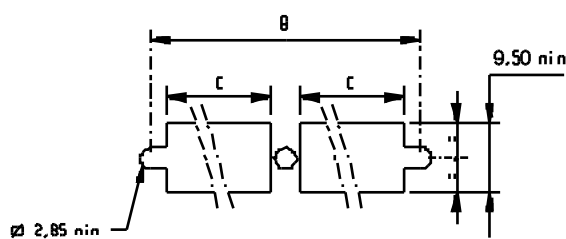

Alternative for float mounting.

**NOTE :**

The marking shown is for a "SOCKET" connector.  
For a "PLUG" connector, the numbers 1, 2, 3 are located at the opposite end.

# SERIES HE 809

## STRAIGHT P.C. FEMALE

### OTHER GUIDE OPTIONS

#### "STANDARD GUIDE STYLES"

#### "FAST CODING"

**Q**

For moulds with 2 or 3 guides. Female jacking fixed unpolarised for termination styles : C1, Y1, Y2, Y3, K2, K3. Centre guide : standard style B. Tightening torque : 0.20 to 0.25 Nm. Mates with jacking guide style P.

**S**

For moulds with 2 or 3 guides. Female with 6 positions of coding for termination styles : C1, Y1, Y2, Y3, K2, K3. Tightening torque : 0.20 to 0.25 Nm. Mates with guide styles A, K, F, AB, L, AB, AC, G. Similar to style B but with a hexagonal rear nut. When used with K style terminations tighten the nut carefully to avoid contact damage.

**T**

For moulds with 2 or 3 guides. Female with 6 positions of coding for termination style : Y1. Tightening torque : 0.20 to 0.25 Nm. Mates with guide styles A, K, F, AB, L, AC, G.

For a 1.6 p.c.b. the guide provides a low profile fixing by the use of a shouldered nut.  
Note : p.c. drilling  $\varnothing 3 \pm 0.1$ .  
The pad  $\varnothing$  should be chosen appropriately.

**W**

For moulds with 2 or 3 guides. Female fast coding with 6 positions for termination styles : C1, Y1, Y2, Y3, K2, K3. Tightening torque : 0.20 to 0.25 Nm. Mates with guide styles A, K, F, AB, L, AC, G. See NOTE 1 and 2.

**X**

For moulds with 2 or 3 guides. Female fast coding with 6 positions for termination styles : C1, Y1, Y2, Y3, K2, K3. Centre guide style B (see page 10). Tightening torque : 0.20 to 0.25 Nm. Mates with guide styles AK, F, AB, L, AC, G. See NOTE 1 and 2.

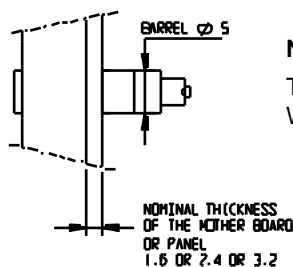

Other options : see Additional 97

When used with a high vibration level, a fixative (Loctite or similar) is recommended to keep the screw tight.

**NOTE 2 :** FOR GUIDE STYLES W AND X

For extender card applications : deduct 0.40 from the termination length.

The "click stop" mechanism permits polarisation changing without guide removal.

Coding changing :

Use the 280 S 02 tool. The coding position is shown by the groove in the tool handle (see page 34).

These guides are assembled to the connector at the factory and cannot be removed. Spare guides are not available separately.

\* Please consult factory.

**STRAIGHT P.C. MALE SOCKET  
STRAIGHT P.C. MALE PLUG**

HE 809 EM 144	A	Y1	G	3	0.8
HE 809 FM 144	A	Y1	G	3	0.8

Number of contacts (sizes)  
026-044-062-080-098-108-126-144-162-180-198

Options :                                      Without stiffening bar

Termination styles

Y1, Y2, Y4

Guide styles

G

Termination finish

Tin alloy

3

**Contact area finish :**

Standard      0.8 micron min. gold thickness (previously B)

0.8

Others \*      1.27 micron min. gold thickness (previously C)

1.2

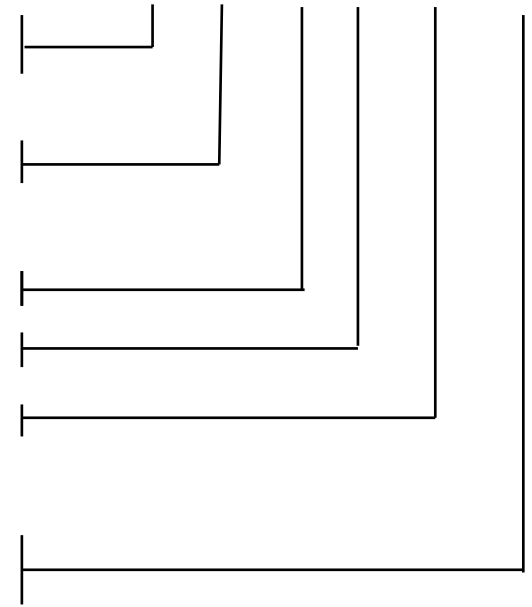

**RIGHT ANGLE FEMALE PLUG AND SMT  
RIGHT ANGLE FEMALE SOCKET AND SMT**

HE 809 FF 098	A	V1	U	3	0.8
HE 809 EF 098	A	V1	U	3	0.8

Number of contacts (sizes)  
026-044-062-080-098-108-126-144-162-180-198

Options :                                      Without stiffening bar

Termination styles

V1, V2, V3, R2

Guide styles

U, Y, Z

Termination finish

Tin alloy

3

**Contact area finish :**

Standard      0.8 micron min. gold thickness (previously B)

0.8

Others \*      1.27 micron min. gold thickness (previously C)

1.2

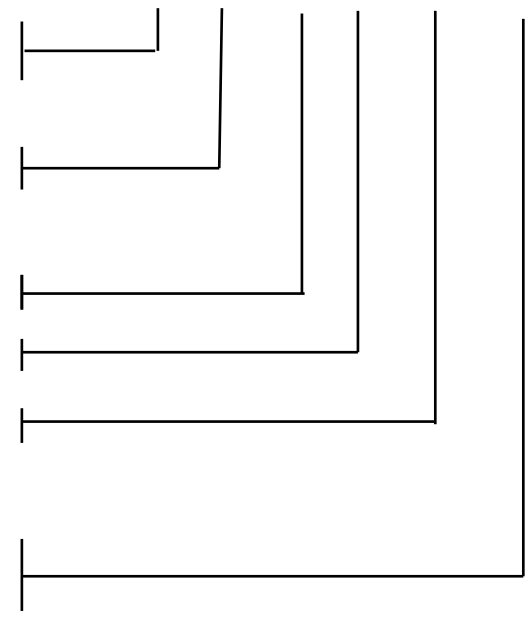

\* Other finishes can be supplied but a minimum contact quantity is required : Please consult factory.

# SERIES HE 809

## STRAIGHT P.C. MALE

### TERMINATION STYLES L.F.

Y•

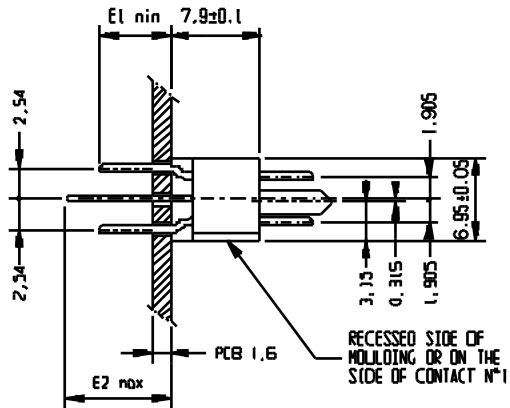

	E1 min.	E2 max.
Y1 : for use with 1.6 p.c.b.	2.9	3.5
Y2 : for use with 2.4 p.c.b.	3.4	4
Y3 : *		
Y4 : for use with 4.4 p.c.b.	5.4	6

Termination : Tin alloy

### OPTIONS

Stiffening	Standard termination	Rear sealing
without	A	Not available

\* NOT AVAILABLE : CONSULT US.

When used with a high vibration level, a fixative (Loctite or similar) is recommended to keep the screw tight.

### STANDARD GUIDE STYLES

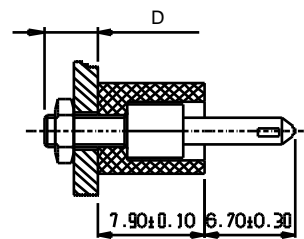

6 positions of coding

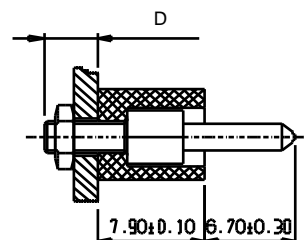

Without coding

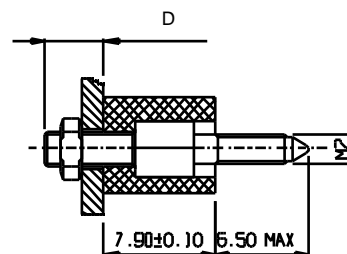

Thread guide

P.c.b. thickness (mm)		1,6	2,4	3,2	4,4
Termination styles		Y1	Y2	( )	Y4
<b>G</b>	All guides	<b>G</b>	<b>G</b>	<b>AE</b>	<b>BQ</b>
	with 6 positions of coding	D=5	D=5	D=6,6	D=7,8
<b>U</b>	6 positions of coding	<b>DA</b>	<b>DA</b>	<b>CC</b>	<b>CD</b>
	Centre : without coding	D=5	D=5	D=7,1	D=7,8
<b>E</b>	All guides	<b>BL</b>	<b>BL</b>	<b>BL</b>	<b>BZ</b>
	Without coding	D=5,5	D=5,5	D=5,5	D=7,8
<b>O</b>	All thread	<b>AG</b>	<b>AG</b>	<b>AG</b>	<b>BX</b>
	TO BE AVOIDED	D=6,6	D=6,6	D=6,6	D=7,8
<b>T</b>	Thread guides	<b>AH</b>	<b>AH</b>	<b>AH</b>	<b>BY</b>
	Centre : 6 positions of coding	D=6,6	D=6,6	D=6,6	D=7,8
<b>N</b>	Thread guides	<b>AJ</b>	<b>AJ</b>	<b>AJ</b>	<b>CE</b>
	Centre : Without coding	D=6,6	D=6,6	D=6,6	D=7,8

Tightening torque : 0,20 à 0,25 Nm

# SERIES HE 809

## MOUNTING DETAILS STRAIGHT P.C. MALE

**From 26 to 98 ways**  
2 GUIDES

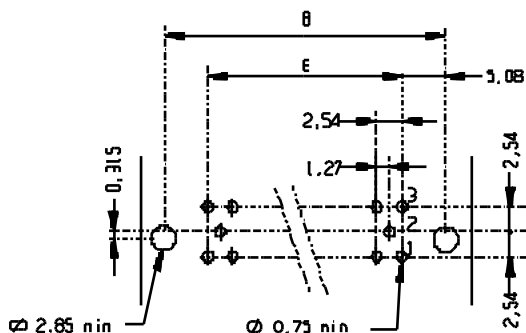

Dimensions for contact style Y.

Sizes	026	044	062	080	098
E	20.32	35.56	50.8	66.04	81.28
B ± 0,2	30.48	45.72	60.96	76.2	91.44

NOTE :

The marking shown is for a "SOCKET" connector.

For a "PLUG" connector the numbers 1, 2, 3 are located at the opposite end.

**From 108 to 198 ways**  
3 GUIDES

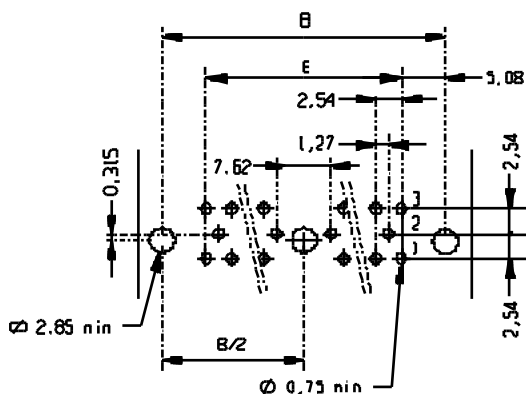

Dimensions for contact style Y.

Sizes	108	126	144	162	180	198
E	96.52	111.76	127	142.24	157.48	172.72
B ± 0,2	106.68	121.92	137.16	152.4	167.64	182.88

NOTE :

The marking shown is for a "SOCKET" connector.

For a "PLUG" connector the numbers 1, 2, 3 are located at the opposite end.



# SERIES HE 809

## RIGHT ANGLE FEMALE AND SMT

### TERMINATION STYLES L.F.

V•

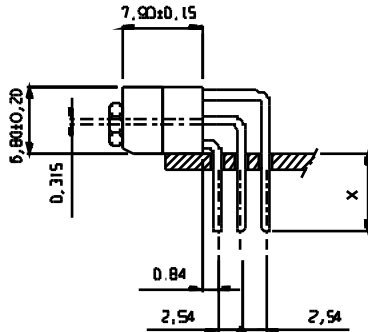

	X	
	min.	max.
V1 : for use with 1.6 p.c.b.	2.6	3.2
V2 : for use with 2.4 p.c.b.	3.4	4.0
V3 : for use with 3.2 p.c.b.	4.2	4.8

Termination : Tin alloy.

R2

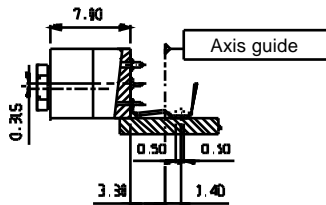

R2 : SMT flexible circuit connection

Termination : Tin alloy

### OPTIONS

Stiffening bar	Standard termination	Rear sealing
Without	Code A	Not available

### STANDARD GUIDE STYLES

U

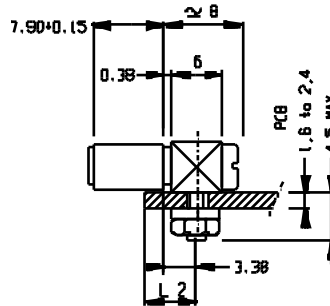

For moulds with 2 or 3 guides.  
Female with 6 positions of coding for termination styles : V1, V2, V3.  
Centre guide AD.  
Tightening torque : 0.20 to 0.25 Nm.  
Mates with guide styles A, K, F, AB, L, AC, G.  
See NOTE 1.

Y

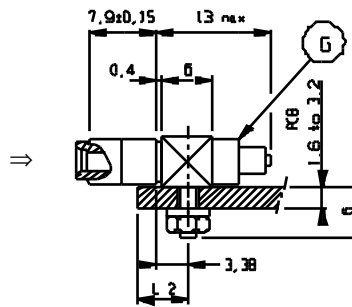

For moulds with 2 or 3 guides.  
Female fast coding with 6 positions for termination styles : V1, V2, V3.  
Centre guide AV.  
Tightening torque : 0.20 to 0.25 Nm.  
Mates with guide styles A, K, F, AB, L, AC, G.  
See NOTE 1 and 2.

Z

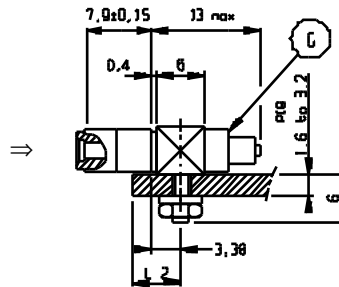

For moulds with 2 or 3 guides.  
Female fast coding with 6 positions for termination styles : V1, V2, V3.  
Centre guide : AD.  
Tightening torque : 0.20 to 0.25 Nm.  
Mates with guide styles A, K, F, AB, L, AC, G.  
See NOTE 1 and 2.

**NOTE 1 :** Top view for guide styles U, Y, Z.

Tightening torque : 0.20 to 0.25 Nm.

End guides : Hexagonal nut G is 5 A/F.

Dim E = 6.

Centre guide : Barrel nut G = Ø 5.

Dim E = 5.

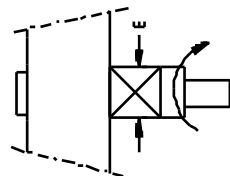

**Other variants : see Additionnal 97**

When used with a high vibration level, a fixative (Loctite or similar) is recommended to keep the screw tight.

**NOTE 2 :** FOR GUIDE STYLES Y AND Z

For extender card applications : deduct 0.40 from the termination length.

The "click stop" mechanism permits polarisation changing without guide removal.

Coding changing :

Use the 280 S 02 tool. The coding position is shown by the groove in the tool handle (see page 34).

These guides are assembled to the connector at the factory and cannot be removed. Spare guides are not available separately.

**MOUNTING DETAILS RIGHT ANGLE FEMALE AND SMT**

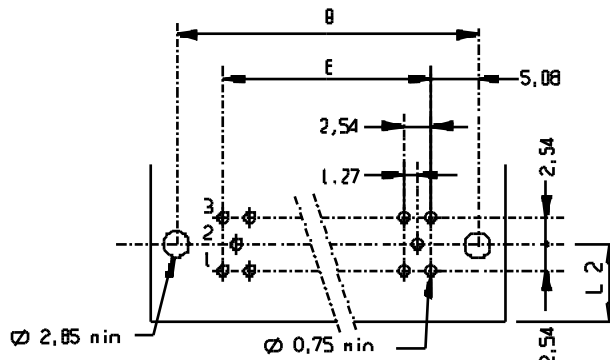

**From 26 to 98 ways**

2 GUIDES

Dimensions for contact style V.

NOTE :

The marking shown is for a "PLUG" connector.

For a "SOCKET" connector the numbers 1, 2, 3 are located at the opposite end.

The p.c.b. should overlap the connector body.

For extender cards the overlap of the 2 p.c.b.'s must be compatible.

Overlap recommended with connector style L2, see page 43.

SIZES	026	044	062	080	098
E	20.32	35.56	50.8	66.04	81.28
B ± 02	30.48	45.72	60.96	76.2	91.44

NOTA : Use aligner tool before inserting contacts through p.c.b.

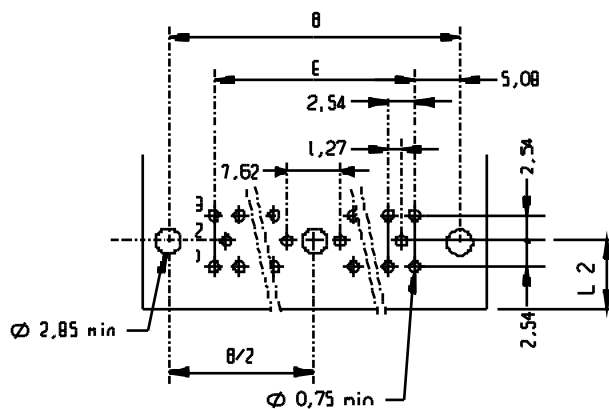

**From 108 to 198 ways**

2 GUIDES

Dimensions for contact style V.

NOTE :

The marking shown is for a "PLUG" connector.

For a "SOCKET" connector the numbers 1, 2, 3 are located at the opposite end.

The p.c.b. should overlap the connector body.

For extender cards the overlap of the 2 p.c.b.'s must be compatible.

Overlap recommended with connector style L2, see page 43.

SIZES	108	126	144	162	180	198
E	96.52	111.76	127	142.24	157.48	172.72
B ± 02	106.68	121.92	137.16	152.4	167.64	182.88

NOTA : Use aligner tool before inserting contacts through p.c.b.

**P.c.b. layout for R2 termination, see Additional 97**

# SERIES HE 810 MOULD SIZES

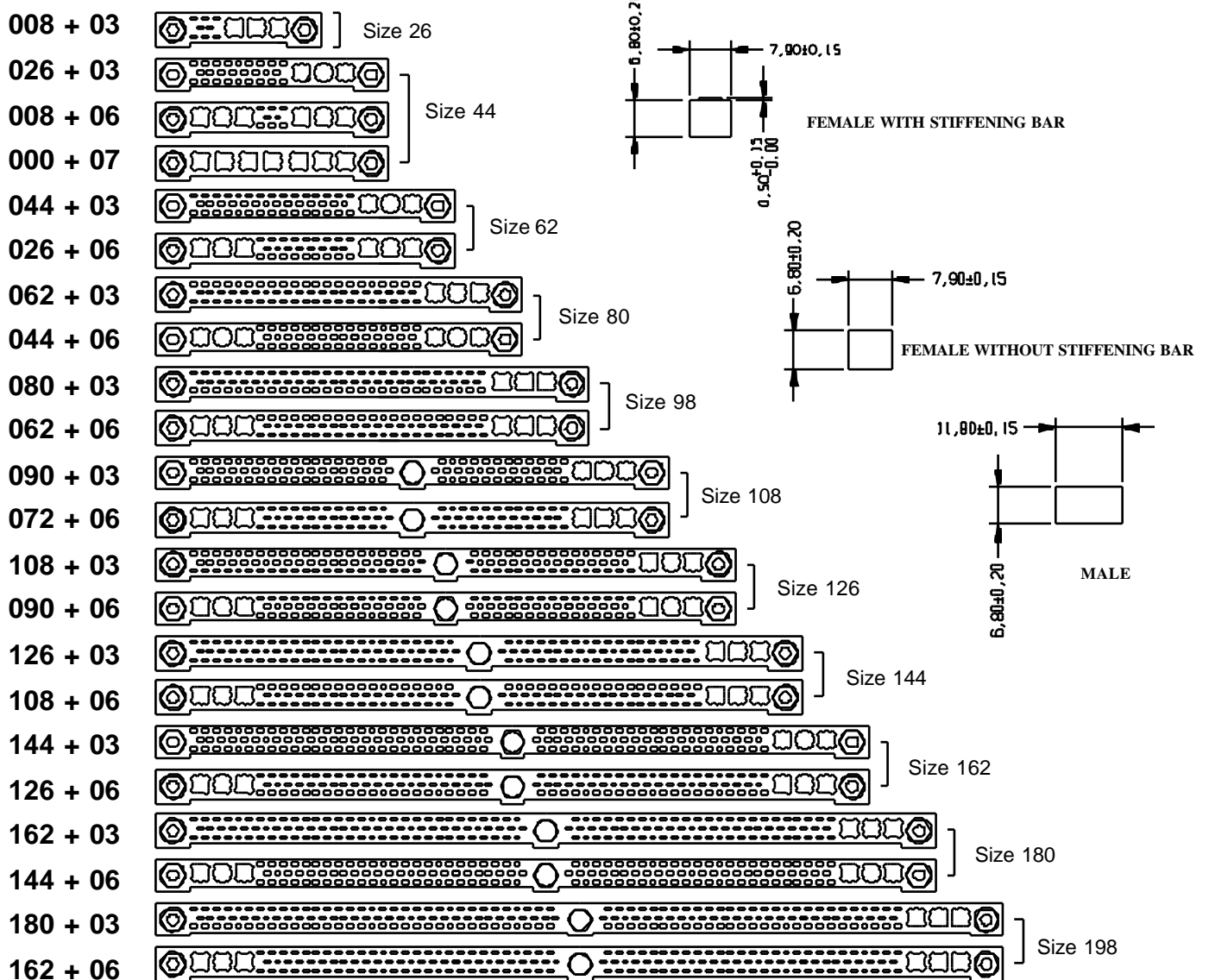
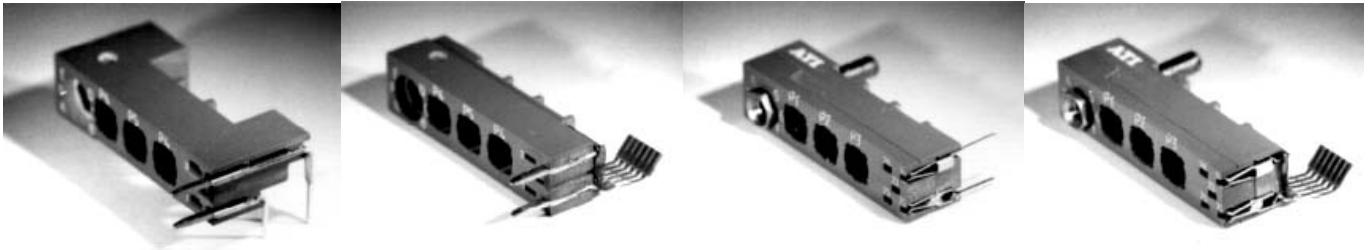

# SERIES HE 810

## DIMENSIONS

### MALE WITH L.F. CONTACTS STYLE V

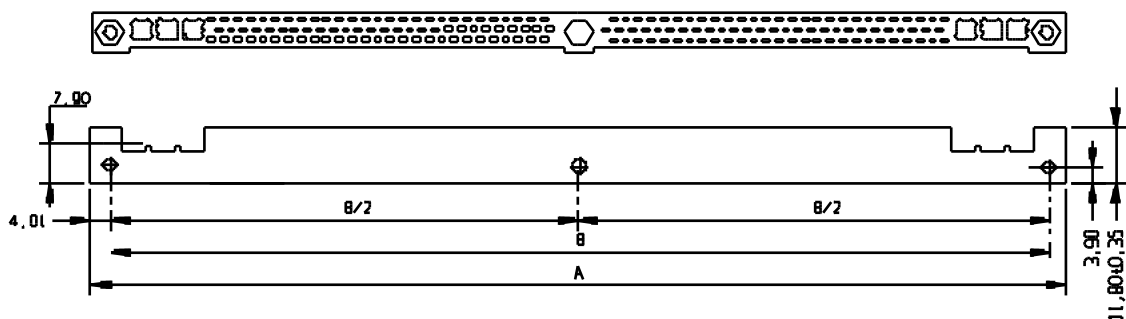

### FEMALE

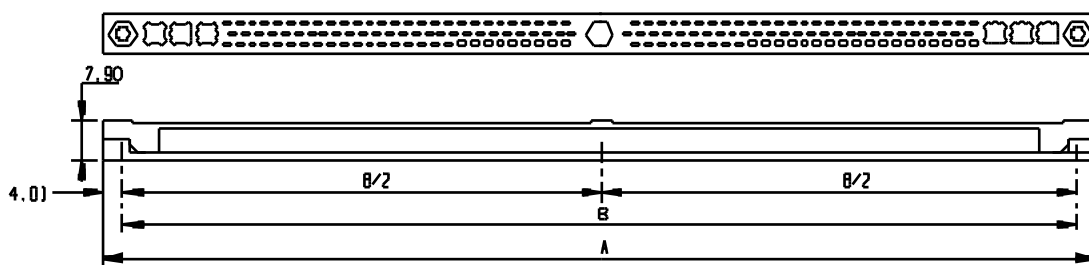

### MALE WITH L.F. CONTACTS STYLE R2 (SMT) : D1 = 11.8

### MALE WITH L.F. CONTACTS STYLE Y1 : D2 = 7.9

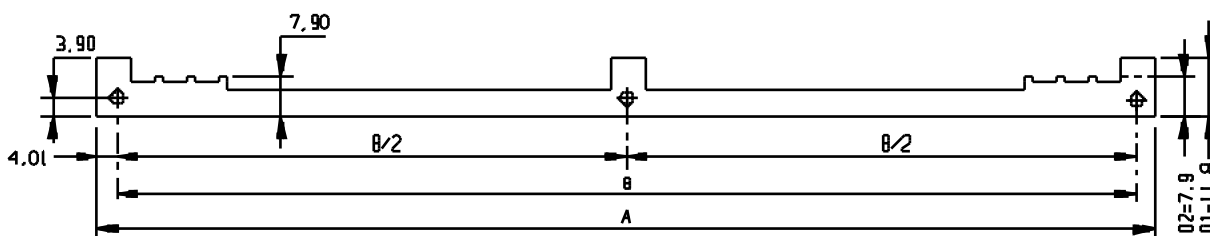

**NOTE :** The mould size relates to the 809 L.F. connector of the same length.

MOULD SIZE	026	044	062	080	098	108	126	144	162	180	198
Arrangement	008+03	026+03 008+06 0 + 07	044+03 026+06	062+03 044+06	080+03 062+06	090+03 072+06	108+03 090+06	126+03 108+06 084+10	144+03 126+06 102+10	162+03 144+06 120+10	180+03 162+06 138+10
A - 0 - 0,4	38.5	53.7	69	84.2	99.5	114.7	129.9	145.2	160.4	175.7	190.9
B ± 0,2	30.48	45.72	60.96	76.20	91.44	106.68	121.92	137.16	152.4	167.64	182.88

**SERIES HE 810**  
**PART NUMBER SYSTEM**

**RIGHT ANGLE AND SMT MALE PLUG**      HE 810 FM 108 03  
06  
10    A V1    A 3 0.8

**RIGHT ANGLE AND SMT MALE SOCKET** HE 810 EM 108 06  
10    A V1    A 3 0.8

Arrangement From size 026 (008 + 03) To size 198 (180 + 03 to 138 + 10) (see pages 5 and 20)	Number of L.F. contacts						
	Number of cavities for special contacts						
Options :	Without stiffening bar    A						
L.F. contacts termination styles	V1, V2, R2						
Guide styles	A, K, F, AB, L, AC, P						
L.F. contacts termination finish	Tin alloy                      3						
<b>Contact area finish :</b>							
Standard :	0.8 micron min. gold thickness (previously B)      0.8						
Others * :	1.27 micron min. gold thickness (previously C)      1.2						

**NOTE : PART NUMBER SIMPLIFIED FOR "0 + 7"**    HE 810 FM      0    07                      A  
(the letter "M" means the sex of the guide, not the sex of contact)

**STRAIGHT P.C. FEMALE SOCKET**      HE 810 EF 144 03  
06  
10    A Y3    B 3 0.8

**STRAIGHT P.C. FEMALE PLUG**      HE 810 FF 144 06  
10    A Y3    B 3 0.8

Arrangement (see pages 5 and 20) From size 026 (008 + 03) To size 198 (180 + 03 to 138 + 10)	Number of L.F. contacts						
	Number of cavities for special contacts						
Options :	Without stiffening bar    A With stiffening bar        B						
Description and conditions of use See page 26							
L.F. contacts termination styles	Y1, Y2, Y3, K2, K3, C1						
Guide styles	B, C, H, J, Q, S, T, W, X						
L.F. contacts termination finish See page 26	Gold                              2 Tin alloy                          3						
<b>Contact area finish :</b>							
Standard :	0.8 micron min. gold thickness (previously B)      0.8						
Others * :	1.27 micron min. gold thickness (previously C)      1.2						

**NOTE : PART NUMBER SIMPLIFIED FOR "0 + 7"**    HE 810 EF      0    07                      B  
(the letter "F" means the sex of the guide, not the sex of contact).

\* Other finishes can be supplied but a minimum contact quantity is required : please consult factory.

# SERIES HE 810

## RIGHT ANGLE AND SMT MALE

### TERMINATIONS STYLES L.F.

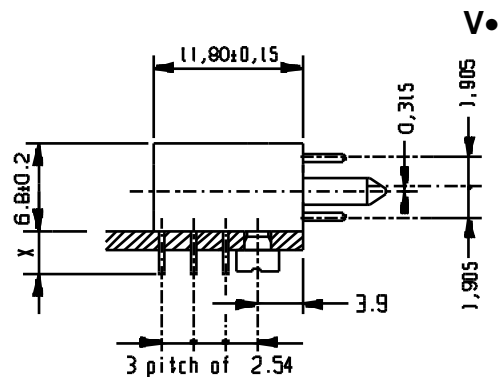

V0

	X	
	min.	max.
V1 : for use with 1.6 p.c.b.	2.6	3.2
V2 : for use with 2.4 p.c.b.	3.4	4

Termination : Tin alloy.

R2

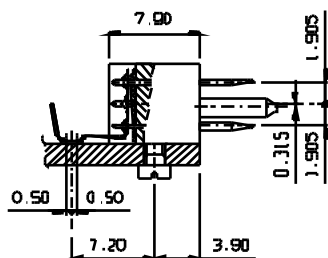

R2 : SMT flexible circuit connection

Termination : Tin alloy.

### OPTIONS

Stiffening bar	Standard termination
Without	Code A

### GUIDE STYLES

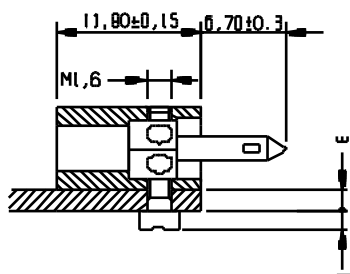

E : p.c.b. thickness 1.6 and 2.4

E : p.c.b. thickness 2.4 and 3.2

**A**  
**K**

For moulds with 2 or 3 guides.

For style V and R.

Tightening torque : 0.07 to 0.09 Nm.

All guides with 6 positions of coding.

Mates with guide styles B, C, H, J, U.

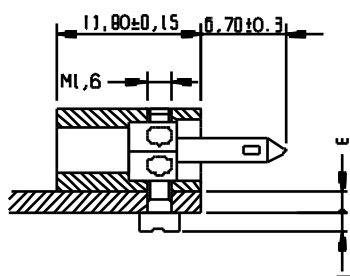

E : p.c.b. thickness 1.6 and 2.4

E : p.c.b. thickness 2.4 and 3.2

**F**  
**AB**

For moulds with 3 guides only.

For style V and R.

Tightening torque : 0.07 to 0,09 Nm.

Centre guide without coding.

Mates with guide styles B, C, H, J, U.

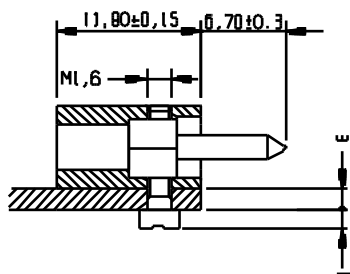

E : p.c.b. thickness 1.6 and 2.4

E : p.c.b. thickness 2.4 and 3.2

**L**  
**AC**

For moulds with 2 or 3 guides.

For extender card only.

Tightening torque : 0.07 to 0.09 Nm.

All guides without coding.

Mates with guide styles B, C, H, J, U.

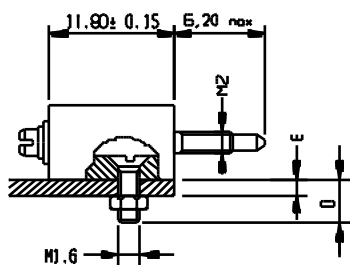

E : p.c.b. thickness 1.6 and 2.4

D : 5

**P**

For moulds with 2 or 3 guides.

For style V and R.

Tightening torque mounting nut : 0.17 to 0.20 Nm.

Guide 0.07 to 0.09 Nm.

Jacking guide without coding.

Centre guide without coding as with guide style L.

Mates with guide style Q.

Other options : see Additional 97

When used with a high vibration level, a fixative (Loctite or similar) is recommended to keep the screw tight.

**MOUNTING DETAILS RIGHT ANGLE MALE AND SMT**

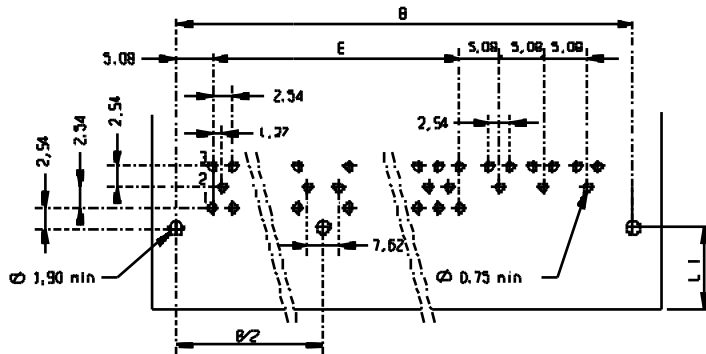

**MIXED LAYOUT WITH 3 COAXIAL**

Dimensions for contact style V.

COAXIAL CONTACT STYLE KMX 3 - M 032

(Power contact - see page 42).

NOTE :  
MARKING "PLUG" ONLY  
(see page 5).

L1 :

Min. : 3

Max. : - When used with a straight p.c. female : 11.50 (see page 4).

- When used with a right angle female or an extender card : 9.50 (see page 43).

Arrangement	008+03	026+03	044+03	062+03	080+03	090+03	108+03	126+03	144+03	162+03	180+03
<b>B</b>	30.48	45.72	60.96	76.20	91.44	106.68	121.92	137.16	152.40	167.64	182.88
<b>E</b>	5.08	20.32	35.56	50.80	66.04	81.28	96.52	111.76	127	142.24	157.48

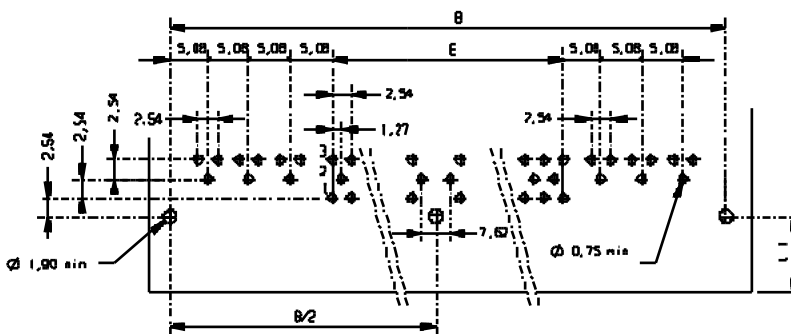

**MIXED LAYOUT WITH 6 COAXIAL**

Dimensions for contact style V.

COAXIAL CONTACT STYLE KMX 3 - M 032

(Power contact - see page 42).

NOTE :  
The marking shown is for a "PLUG" connector.  
For a "SOCKET" connector the numbers 1, 2, 3 are located at the opposite end ; see page 5.

L1 :

Min. : 3

Max. : - When used with a straight p.c. female : 11.50 (see page 4).

- When used with a right angle female or an extender card : 9.50 (see page 43).

Arrangement	008+06	026+06	044+06	062+06	072+06	090+06	108+06	126+06	144+06	162+06
<b>B</b>	45.72	60.96	76.2	91.44	106.68	121.92	137.16	152.40	167.64	182.88
<b>E</b>	5.08	20.32	35.56	50.80	66.04	81.28	96.52	111.76	127	142.24

P.c.b. layout for R2 termination, see Additionaln 97

## NOTES



# SERIES HE 810

## MOUNTING DETAILS SMT MALE

---

MIXED LAYOUT WITH 3  
COAXIAL

See Additionnal 97

COAXIAL CONTACT STYLE  
KMX 3 - M 172

---

MIXED LAYOUT WITH 6  
COAXIAL

See Additionnal 97

COAXIAL CONTACT STYLE  
KMX 3 - M 172

# SERIES HE 810

## SOLDER, P.C. (STRAIGHT) & WIRE WRAPPING FEMALE

### TERMINATION STYLES L.F.

### STANDARD GUIDE STYLES

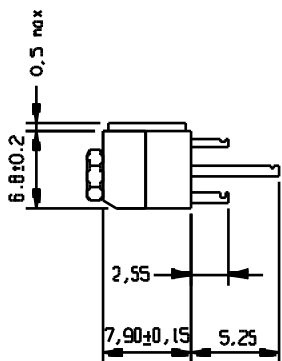

**C1**

Termination : Tin alloy.

C1 : Solder wire  $\varnothing$  0.6 max. (24 AWG).

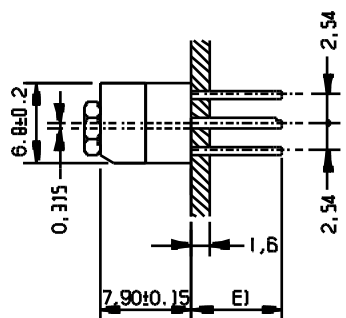

**Y0**

Termination : Tin alloy.

E1

	min.	max.
Y1 : for use with 1.6 p.c.b.	2.6	3.2
Y2 : for use with 2.4 p.c.b.	3.4	4
Y3 : for use with 3.2 p.c.b.	4.2	4.8
Y4 : for use with 4,5 p.c.b.	5.7	6.15
Y6 : for use with 8.5 p.c.b. Drilling diameter on p.c.b. 0.9 mm	9.7	10.15

SECTION



**K0**

Termination : Gold

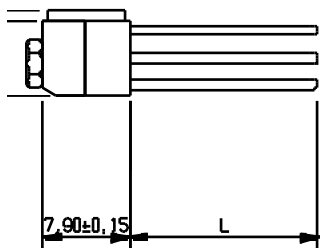

Wire wrapping terminations

K2 : 2 wraps L = 10.65

K3 : 3 wraps L = 14.60

### OPTIONS

Stiffening bar	Standard termination	Rear sealing
WITHOUT	Code A	Not available
WITH	Code B	

NOTE : The stiffening bar is standard with C and K styles for 80 ways and above.

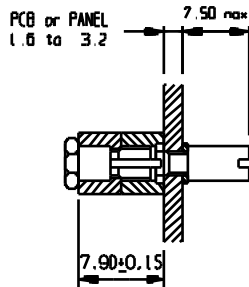

**B**

For moulds with 2 or 3 guides. Female with 6 positions of coding for termination styles C1, Y1, Y2, Y3 (K2, K3).  
Tightening torque : 0.20 to 0.25 Nm.  
Mates with guide styles A, K, F, AB, L, AC, G.  
(See guide S - page 12).

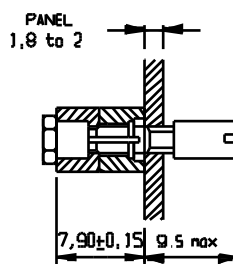

**C**

For moulds with 2 or 3 guides. Floating female with 6 positions of coding for termination styles C1, K2, K3.  
Tightening torque : 0.07 to 0.09 Nm.  
Mates with guide styles A, K, F, AB, L, AC, G.

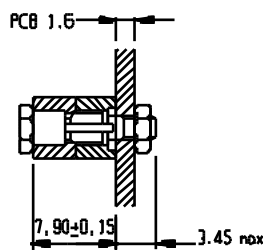

**H**

For moulds with 2 or 3 guides. Female with 6 positions of coding for termination style Y1.  
Tightening torque : 0.20 to 0.25 Nm.  
Mates with guide styles A, K, F, AB, L, AC, G.

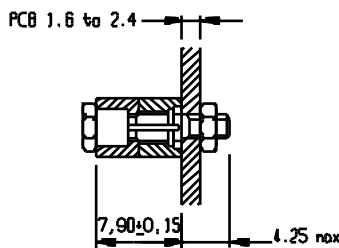

**J**

For moulds with 2 or 3 guides. Female with 6 positions of coding for termination styles Y1, Y2.  
Tightening torque : 0.20 to 0.25 Nm.  
Mates with guide styles A, K, F, AB, L, AC, G.  
P.c.b. thickness 3.2.  
(See guide S - page 12).

Other guide styles, see page 12 and Additional 97

For modification to the polarising - see page 34.

When used with a high vibration level, a fixative (Loctite or similar) is recommended to keep the screw tight.



# SERIES HE 810

## STRAIGHT P.C. FEMALE

### OTHER GUIDE VARIANTS

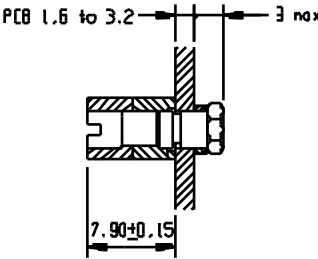
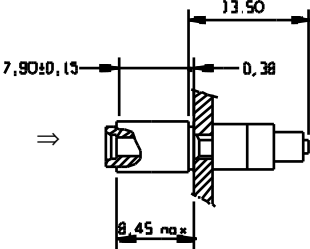
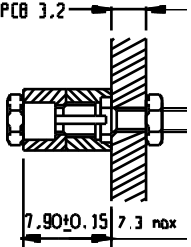
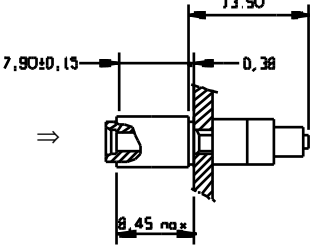
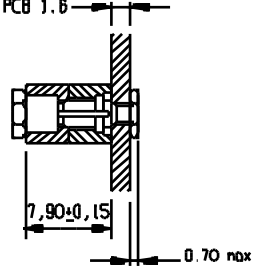
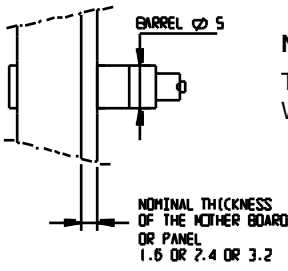
"STANDARD GUIDE STYLES"	"FAST CODING"
<p style="text-align: right;"><b>Q</b></p>  <p>PCB 1.6 to 3.2 — 3 max</p> <p>For moulds with 2 or 3 guides. Female jacking fixed without coding for termination styles : C1, Y1, Y2, Y3, K2, K3. Centre guide : standard style B. Tightening torque : 0.20 to 0.25 Nm. Mates with jacking guide style P.</p>	<p style="text-align: right;"><b>W</b></p>  <p>For moulds with 2 or 3 guides. Female fast with 6 positions of coding for termination styles : C1, Y1, Y2, Y3, K2, K3. Tightening torque : 0.20 to 0.25 Nm. Mates with guide styles A, K, F, AE, L, AC, G. See NOTE 1 and 2.</p>
<p style="text-align: right;"><b>S</b></p>  <p>PCB 3.2</p> <p>For moulds with 2 or 3 guides. Female with 6 positions of coding for termination styles C1, Y1, Y2, Y3, K2, K3. Tightening torque : 0.20 to 0.25 Nm. Mates with guides styles A, K, F, AB, L, AB, AC, G. Similar to style B but with a hexagonal rear nut. When used with K style termination tighten the nut carefully to avoid contact damage.</p>	<p style="text-align: right;"><b>X</b></p>  <p>For moulds with 2 or 3 guides. Female fast with 6 positions of coding for termination styles C1, Y1, Y2, Y3, K2, K3. Centre guide style B (see page 10). Tightening torque : 0.20 to 0.25 Nm. Mates with guide styles AK, F, AE, L, AC, G. See NOTE 1 and 2.</p>
<p style="text-align: right;"><b>T*</b></p>  <p>PCB 1.6</p> <p>For moulds with 2 or 3 guides female with 6 positions of coding for termination style : Y1. Tightening torque : 0.20 to 0.25 Nm. Mates with guide styles A, K, F, AB, L, AC, G.</p> <p>For a 1.6 p.c.b. the guide provides a low profile fixing by the use of shouldered nut. Note : p.c. drilling <math>\varnothing 3 \pm 0.1</math>. The pad <math>\varnothing</math> should be chosen appropriately.</p>	<p style="text-align: right;"><b>NOTE 1 :</b></p>  <p>Top view for guide styles W and X.</p> <p><b>NOTE 1 :</b> Top view for guide styles W and X.</p> <p>Other options : see Additional 97</p> <p>When used with a high vibration level, a fixative (Loctite or similar) is recommended to keep the screw tight.</p>

#### NOTE 2 : FOR GUIDE STYLES W AND X

For extender card applications : deduct 0.40 from the termination length.

The "click stop" mechanism permits polarisation changing without guide removal.

Coding changing :

Use the 280 S 02 tool. The coding position is shown by the groove in the tool handle (see page 34).

These guides are assembled to the connector at the factory and cannot be removed. Spare guides are not available separately.

\* Please consult factory.

# SERIES HE 810 PART NUMBER SYSTEM

## STRAIGHT P.C. MALE SOCKET

03  
**HE 810 FM 108** 06 **A Y1 G 3 0.8**  
10

## STRAIGHT P.C. MALE PLUG

**HE 810 EM 108** 06 **A Y1 G 3 0.8**  
10

Arrangement :  
 From size 026 (008 + 03)  
 To size 198 (180 + 03 à 138 + 10)  
 (See pages 5 and 20)

Number of L.F. contacts

Number of cavities for special contacts

Options :

Without stiffening bar      A

L.F. contacts termination styles

Y1, Y2, Y4

Guide styles

G

L.F. contacts termination finish

Tin alloy

3

### Contact area finish :

Standard : 0.8 micron min. gold thickness (previously B)

0.8

Others \* : 1.27 micron min. gold thickness (previously C)

1.2

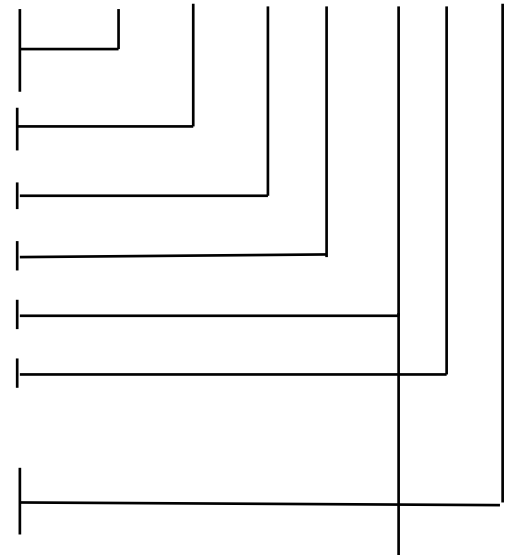

**NOTE : PART NUMBER SIMPLIFIED FOR "0 + 7 "**      **HE 810 FM      0      07      G**  
 (the letter "M" means the sex of the guide, not the sex of contact)

## STRAIGHT P.C. FEMALE SOCKET AND SMT

06  
**HE 810 EF 144** 06 **A V1 U 3 0.8**  
10

## STRAIGHT P.C. FEMALE PLUG AND SMT

**HE 810 FF 144** 06 **A V1 U 3 0.8**  
10

Arrangement :  
 From size 026 (008 + 03)  
 To size 198 (180 + 03 à 138 + 10)  
 (See pages 5 and 20)

Number of L.F. contacts

Number of cavities for special contacts

Options

Without stiffening bar      A

L.F. contacts termination styles

V1, V2, V3, R2

Guide styles

U, Y, Z

L.F. contacts termination finish

Tin alloy

3

### Contact area finish :

Standard : 0.8 micron min. gold thickness (previously B)

0.8

Others \* : 1.27 micron min. gold thickness (previously C)

1.2

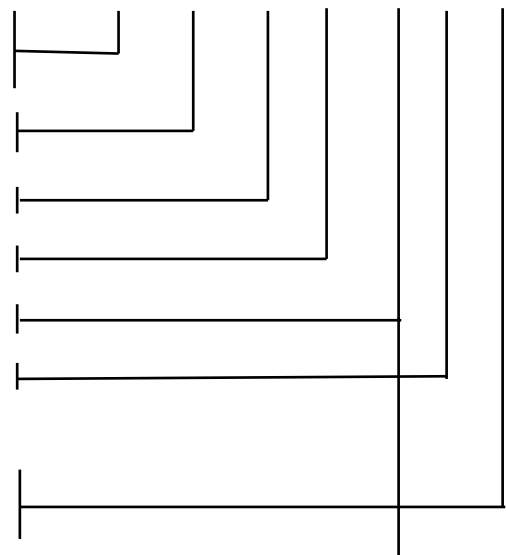

**NOTE : PART NUMBER SIMPLIFIED FOR "0 + 7 "**      **HE 810 EF      0      07      U**  
 (the letter "F" means the sex of the guide, not the sex of contact)

\* Other finishes can be supplied but a minimum contact quantity is required : please consult factory.

# SERIES HE 810

## STRAIGHT P.C. MALE

### TERMINATION STYLES L.F.

Y•

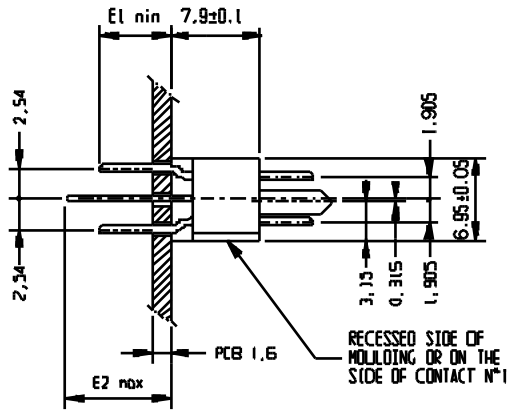

	E1 min.	E2 max.
Y1 : for use with 1,6 p.c.b.	2,9	3,5
Y2 : for use with 2,4 p.c.b.	3,4	4
Y3 : *		
Y4 : for use with 4,4 p.c.b.	5,4	6

Termination : Tin alloy

### OPTIONS

Stiffening	Standard termination	Rear sealing
without	A	Not available

\* NOT AVAILABLE : CONSULT US.

When used with a high vibration level, a fixative (Loctite or similar) is recommended to keep the screw tight.

### STANDARD GUIDE STYLES

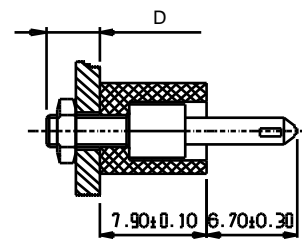

6 positions of coding

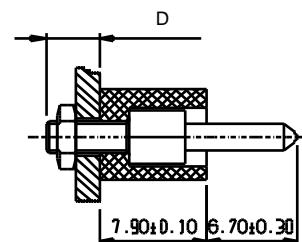

Without coding

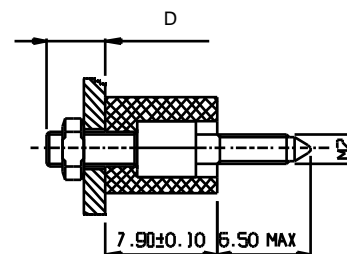

Thread guide

P.c.b. thickness (mm)		1,6	2,4	3,2	4,4
Termination styles		Y1	Y2	( )	Y4
<b>G</b>	All guides	<b>G</b>	<b>G</b>	<b>AE</b>	<b>BQ</b>
	with 6 positions of coding	D=5	D=5	D=6,6	D=7,8
<b>U</b>	6 positions of coding	<b>DA</b>	<b>DA</b>	<b>CC</b>	<b>CD</b>
	Centre : without coding	D=5	D=5	D=7,1	D=7,8
<b>E</b>	All guides	<b>BL</b>	<b>BL</b>	<b>BL</b>	<b>BZ</b>
	Without coding	D=5,5	D=5,5	D=5,5	D=7,8
<b>O</b>	All thread	<b>AG</b>	<b>AG</b>	<b>AG</b>	<b>BX</b>
	TO BE AVOIDED	D=6,6	D=6,6	D=6,6	D=7,8
<b>T</b>	Thread guides	<b>AH</b>	<b>AH</b>	<b>AH</b>	<b>BY</b>
	Centre : 6 positions of coding	D=6,6	D=6,6	D=6,6	D=7,8
<b>S</b>	Thread guides	<b>AJ</b>	<b>AJ</b>	<b>AJ</b>	<b>CE</b>
	Centre : Without coding	D=6,6	D=6,6	D=6,6	D=7,8

Tightening torque : 0,20 à 0,25 Nm

# SERIES HE 810

## MOUNTING DETAILS STRAIGHT P.C. MALE

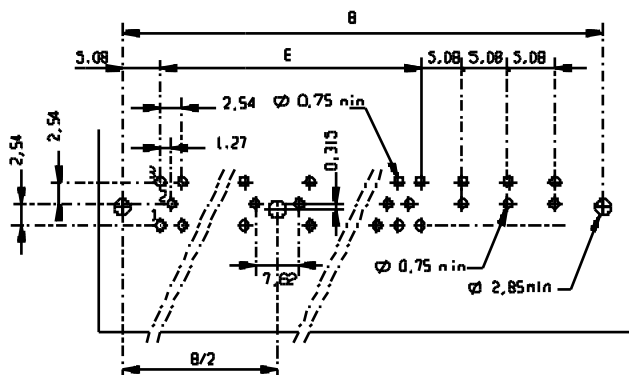

### MIXED LAYOUT WITH 3 COAXIAL

Dimensions for contact style Y

COAXIAL CONTACT STYLE  
KMx3 - M 041

(Power insert - see page 42)

NOTE :  
MARKING "PLUG" ONLY (see page 5)

Arrangement	008+03	026+03	044+03	062+03	080+03	090+03	108+03	126+03	144+03	162+03	180+03
<b>B</b>	30,48	45,72	60,96	76,20	91,44	106,68	121,92	137,16	152,40	167,64	182,88
<b>E</b>	5,08	20,32	35,56	50,80	66,04	81,28	96,52	111,76	127	142,24	157,48

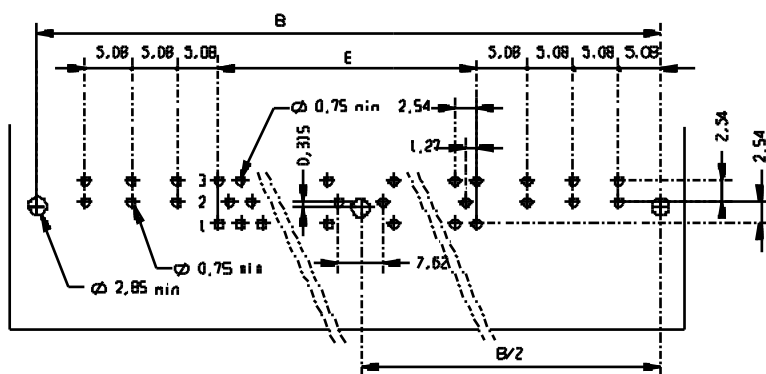

### MIXED LAYOUT WITH 6 COAXIAL

Dimensions for contact style Y

COAXIAL CONTACT STYLE  
KMx3 - M041

(Power insert - see page 42)

NOTE :  
The marking shown is for a "PLUG" connector.  
For a "SOCKET" connector the numbers 1, 2, 3 are located at the opposite end.

Arrangement	008+06	026+06	044+06	062+06	072+06	090+06	108+06	126+06	144+06	162+06
<b>B</b>	45,72	60,96	76,2	91,44	106,68	121,92	137,16	152,40	167,64	182,88
<b>E</b>	5,08	20,32	35,56	50,80	66,04	81,28	96,52	111,76	127	142,24

# SERIES HE 810

## RIGHT ANGLE FEMALE AND SMT

### TERMINATION STYLES L.F.

V•

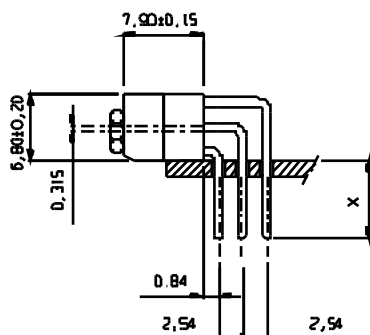

	X	
	min.	max.
V1 : for use with 1.6 p.c.b.	2.6	3.2
V2 : for use with 2.4 p.c.b.	3.4	4.0
V3 : for use with 3.2 p.c.b.	4.2	4.8

Termination : Tin alloy.

R2

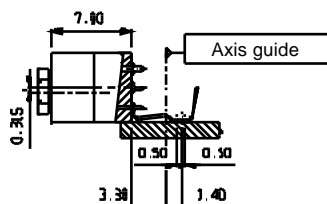

R2 : SMT flexible circuit connection

Termination : Tin alloy

### OPTIONS

Stiffening bar	Standard termination	Rear sealing
Without	Code A	Not available

### STANDARD GUIDE STYLES

U

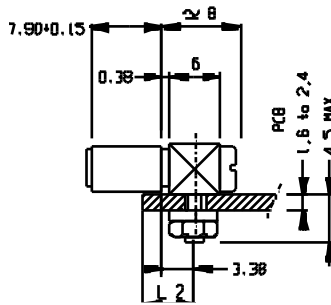

For moulds with 2 or 3 guides.  
Female with 6 positions of coding for termination styles : V1, V2, V3.

Centre guide AD.

Tightening torque : 0.20 to 0.25 Nm.

Mates with guide styles A, K, F, AB, L, AC, G.

See NOTE 1.

Y

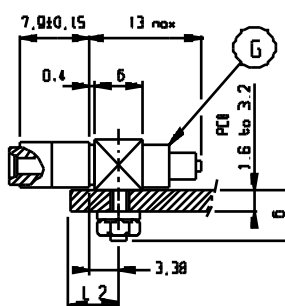

For moulds with 2 or 3 guides.

Female fast coding with 6 positions for termination styles : V1, V2, V3.

Centre guide AV.

Tightening torque : 0.20 to 0.25 Nm.

Mates with guide styles A, K, F, AB, L, AC, G.

See NOTE 1 and 2.

Z

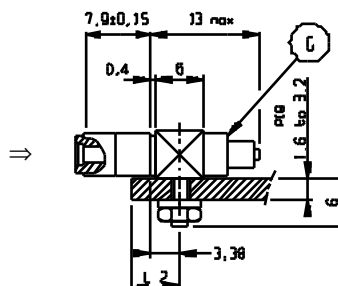

For moulds with 2 or 3 guides.

Female fast coding with 6 positions for termination styles : V1, V2, V3.

Centre guide : AD.

Tightening torque : 0.20 to 0.25 Nm.

Mates with guide styles A, K, F, AB, L, AC, G.

See NOTE 1 and 2.

**NOTE 1** : Top view for guide styles U, Y, Z.

Tightening torque : 0.20 to 0.25 Nm.

End guides : Hexagonal nut G is 5 A/F.

Dim E = 6.

Centre guide : Barrel nut G = Ø 5.

Dim E = 5.

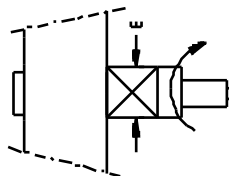

Other options : see Additional 97

When used with a high vibration level, a fixative (Loctite or similar) is recommended to keep the screw tight.

### NOTE 2 : FOR GUIDE STYLES Y AND Z

For extender card applications : deduct 0.40 from the termination length.

The "click stop" mechanism permits polarisation changing without guide removal.

Coding changing :

Use the 280 S 02 tool. The coding position is shown by the groove in the tool handle (see page 34).

These guides are assembled to the connector at the factory and cannot be removed. Spare guides are not available separately.





# SERIES HE 810

## OPERATING INSTRUCTIONS FOR CODING ADJUSTMENT

### MALE CONNECTORS

- Remove the guide fixing screw (except guide G).
- (Guide G) remove the rear nut.
- Remove the guide from its cavity and replace in the correct position.
- Replace the screw and the nut and tighten to the recommended torque.

### FEMALE CONNECTORS

- Use the 280 S 02 tool illustrated below for steps (5) (6) (7)

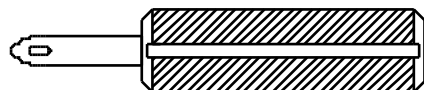

← groove indicates polarising position

- Proceed sequentially for card guide
- Follow the numbered steps from (1) to (14) (example is for a straight guide).

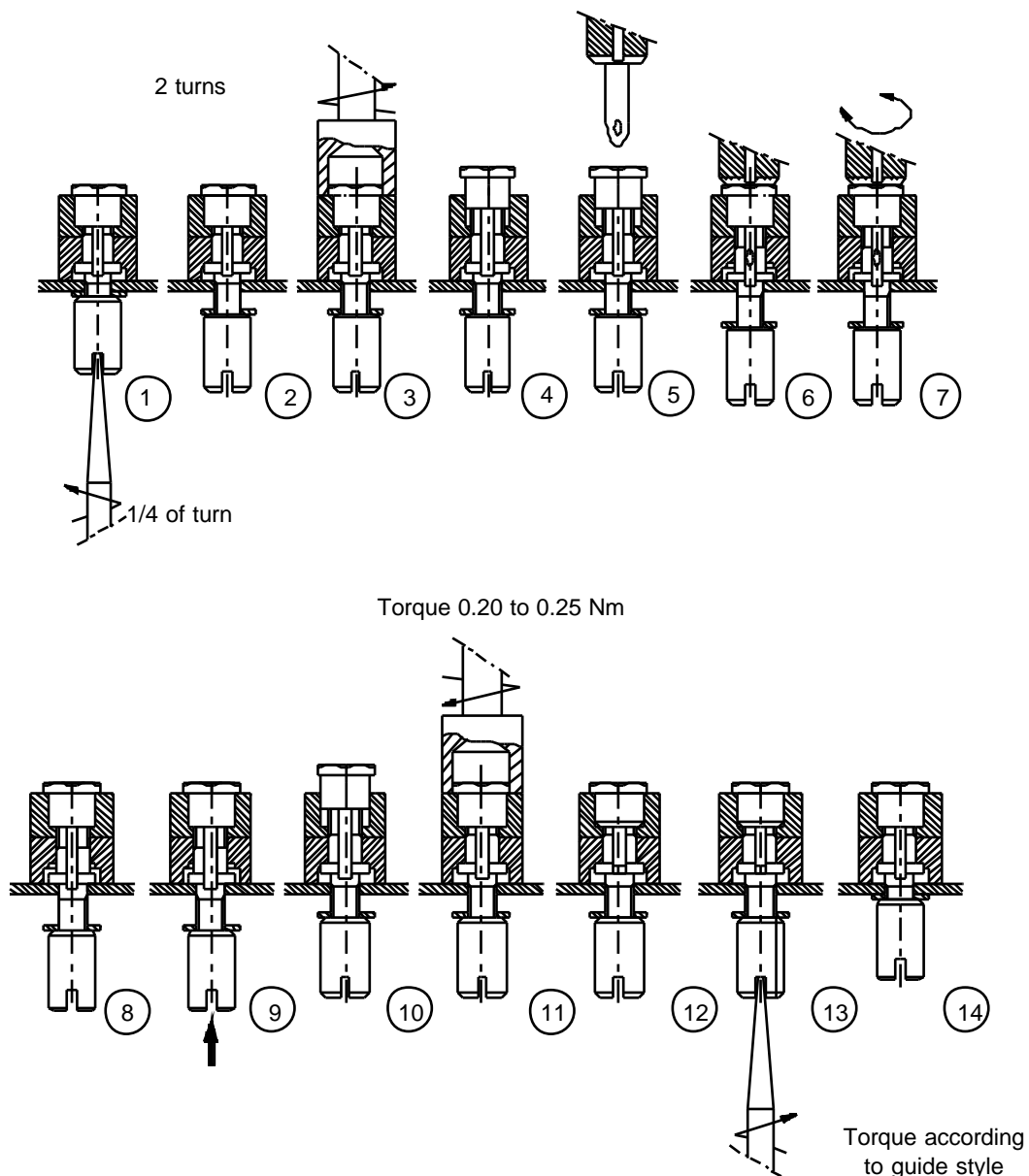

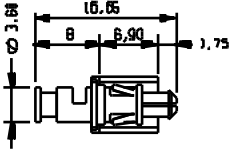
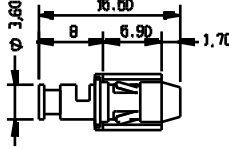
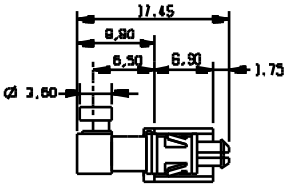
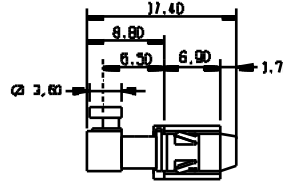
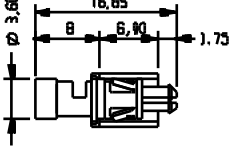
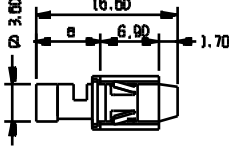
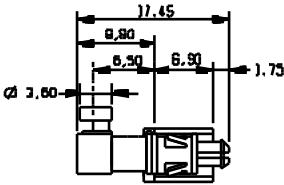
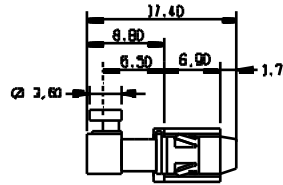
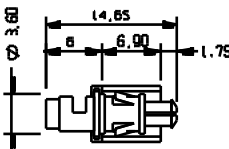
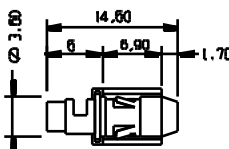
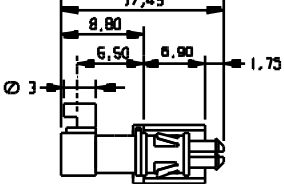
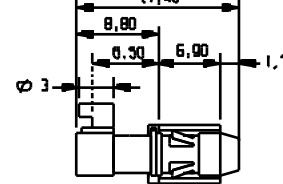
MALE		FEMALE
<p><b>KMX 3 - M 081</b></p> 	<p>Male and female contacts for chassis or free connector assembly. Suitable for flexible cable <math>\varnothing</math> 1.9 max. Réf. KX 21 A (RG 178 B/U or RG 196)</p>	<p><b>KMX 3 - F 081</b></p> 
<p><b>KMX 3 - M 092</b></p> 	<p>Male and female contacts with 90° cable entry for chassis or free connector assembly. Suitable for flexible cable <math>\varnothing</math> 1.9 max. Réf. KX 21 A (RG 178 B/U or RG 196) Usable with mother board, thickness 3.2 mm max.</p>	<p><b>KMX 3 - F 092</b></p> 
<p><b>KMX 3 - M 101</b></p> 	<p>Male and female contacts for chassis or free connector assembly. Suitable for flexible cable <math>\varnothing</math> 2.5 max. Réf. KX 22 A (RG 316).</p>	<p><b>KMX 3 - F 101</b></p> 
<p><b>KMX 3 - M 112</b></p> 	<p>Male and female contacts with 90° cable entry for chassis or free connector assembly. Suitable for flexible cable <math>\varnothing</math> 2.5 max. Réf. KX 22 A (RG 316). Usable with mother board thickness 3.2 mm max.</p>	<p><b>KMX 3 - F 112</b></p> 
<p><b>KMX 3 - M 131</b></p> 	<p>Male and female contacts for chassis or free connector assembly. Suitable for semi-rigid cable <math>\varnothing</math> 2.2 max. Réf. KS 1 (RG 405 - UT 85).</p>	<p><b>KMX 3 - F 131</b></p> 
<p><b>KMX 3 - M 142</b></p> 	<p>Male and female contacts with 90° cable entry for chassis or free connector assembly. Suitable for semi-rigid cable <math>\varnothing</math> 2.2 max. Réf. KS 1 (RG 405 - UT 85). Usable with mother board thickness 3.2 mm max.</p>	<p><b>KMX 3 - F 142</b></p> 

# SERIES HE 810

## H.F. COAXIAL CONTACTS

### KMX 3 SERIES SPECIFICATION NFC 93569 FOR NON-STANDARD CABLES

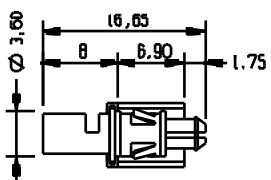
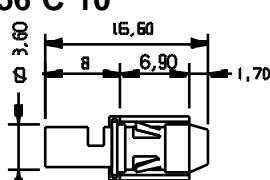
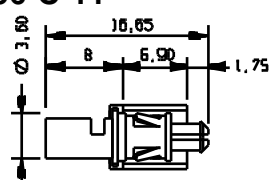
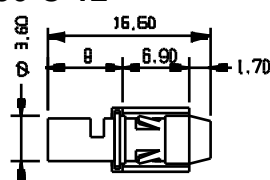
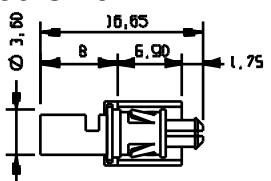
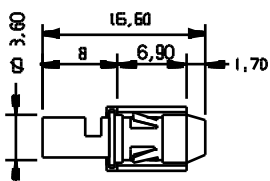
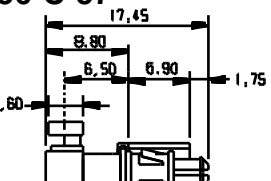
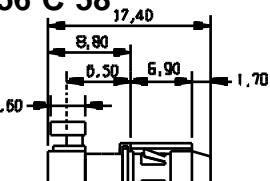
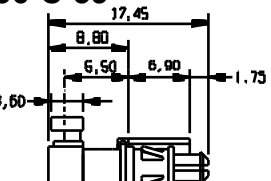
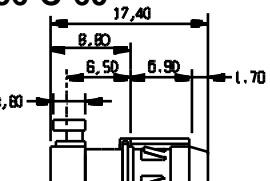
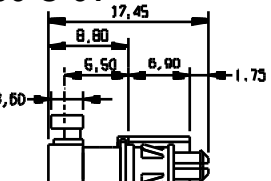
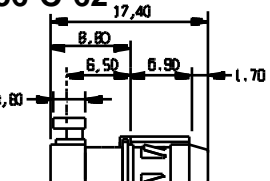
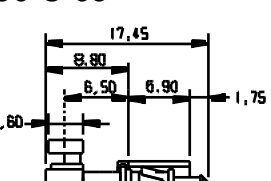
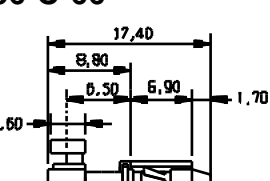
MALE		FEMALE
<p><b>E 756 C 09</b></p> 	<p>Male and female contacts for chassis or free connector assembly. Suitable for flexible cable <math>\varnothing</math> 2.5 max. Réf. Microdot 250-3908</p>	<p><b>E 756 C 10</b></p> 
<p><b>E 756 C 11</b></p> 	<p>Male and female contacts for chassis or free connector assembly. Suitable for flexible cable <math>\varnothing</math> 3.5 max. Réf. Microdot 250-3937</p>	<p><b>E 756 C 12</b></p> 
<p><b>E 756 C 15</b></p> 	<p>Male and female contacts for chassis or free connector assembly. Suitable for flexible extended dielectric cable <math>\varnothing</math> 2.2 max. Réf. Axon P 812817 Réf. Alpen A 22 DT Réf. Gore CSS 1022 K*</p>	<p><b>E 756 C 16</b></p> 
<p><b>E 756 C 57</b></p> 	<p>Male and female contacts with 90° cable entry for chassis or free connector assembly. Suitable for flexibel cable <math>\varnothing</math> 2.8. Réf. KX 22 A "double screen". Usable with mother board thickness 3.2 mm max.</p>	<p><b>E 756 C 58</b></p> 
<p><b>E 756 C 59</b></p> 	<p>Male and female contacts with 90° cable entry for chassis or free connector assembly. Suitable for flexible cable <math>\varnothing</math> 2.5. Réf. Microdot 250-3908. Usable with mother board thickness 3.2 mm max.</p>	<p><b>E 756 C 60</b></p> 
<p><b>E 756 C 61</b></p> 	<p>Male and female contacts with 90° cable entry for chassis or free connector assembly. Suitable for flexible cable <math>\varnothing</math> 3.25. Réf. Microdot 250-3937. Usable with mother board thickness 3.2 mm max.</p>	<p><b>E 756 C 62</b></p> 
<p><b>E 756 C 65</b></p> 	<p>Male and female contacts with 90° cable entry for free connector assembly. Suitable for flexible extended dielectric cable <math>\varnothing</math> 2.2 max. Réf. Axon P 812817 Réf. Alpen A 22 DT Réf. Gore CSS 1022 K* Usable with mother board thickness 3.2 mm max.</p>	<p><b>E 756 C 66</b></p> 

\* For automatic stripping.

# H.F. COAXIAL CONTACTS

KMX 3 SERIES SPECIFICATION NFC 93569 FOR P.C.B.

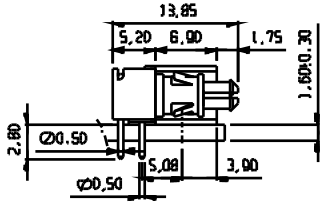
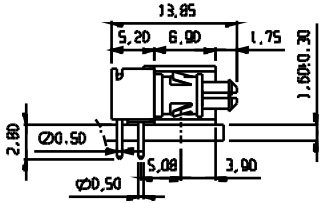
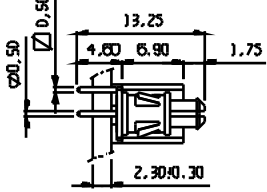
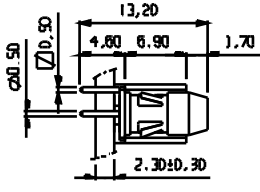
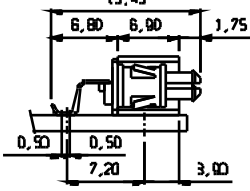
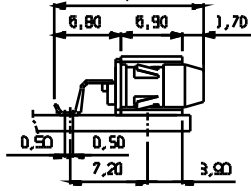
MALE		FEMALE
<p><b>KMX 3 - M 032</b></p> 	<p>Male and female contacts with tails at 90° for direct mounting on to p.c.b. (Cut one of the two ground tails for mounting on to p.c.b.).</p> <p>P.c.b. thickness 3,70 ± 0,30 ;</p> <p>← <b>E756 C20</b>    <b>E756 C24</b> →</p>	<p><b>KMX 3 - F 032</b></p> 
<p><b>KMX 3 - M 041</b></p> 	<p>Male and female contacts with p.c. tails for direct mounting on to p.c.b.</p> <p>P.c.b. thickness 4 ± 0,30 ;</p> <p>← <b>E756 C17</b>    <b>E756 C18</b> →</p> <p>P.c.b. thickness 5 ± 0,30 ;</p> <p>← <b>E756 C30</b>    <b>E756 C29</b> →</p>	<p><b>KMX 3 - F 041</b></p> 
<p><b>KMX 3 - M 172</b></p>  <p>See note 1</p>	<p>Male and female contacts with SMT termination.</p>	<p><b>KMX 3 - F 172</b></p>  <p>See note 1</p>

**NOTE 1 :** Item delivered in special package in order to project the terminations (SMT).  
 - pre-insert the contact on the moulding with help of the protection : see drawings 1 and 2 ;  
 - or extract the contact according to drawing 3.

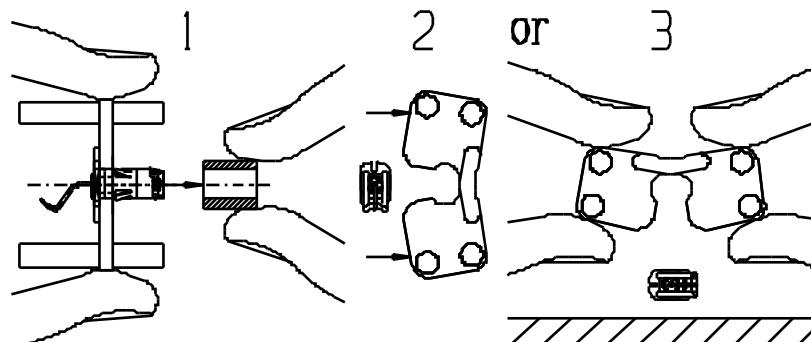

# SERIES HE 810

## INTERCHANGEABILITY

### FEMALE COAXIAL CONTACT

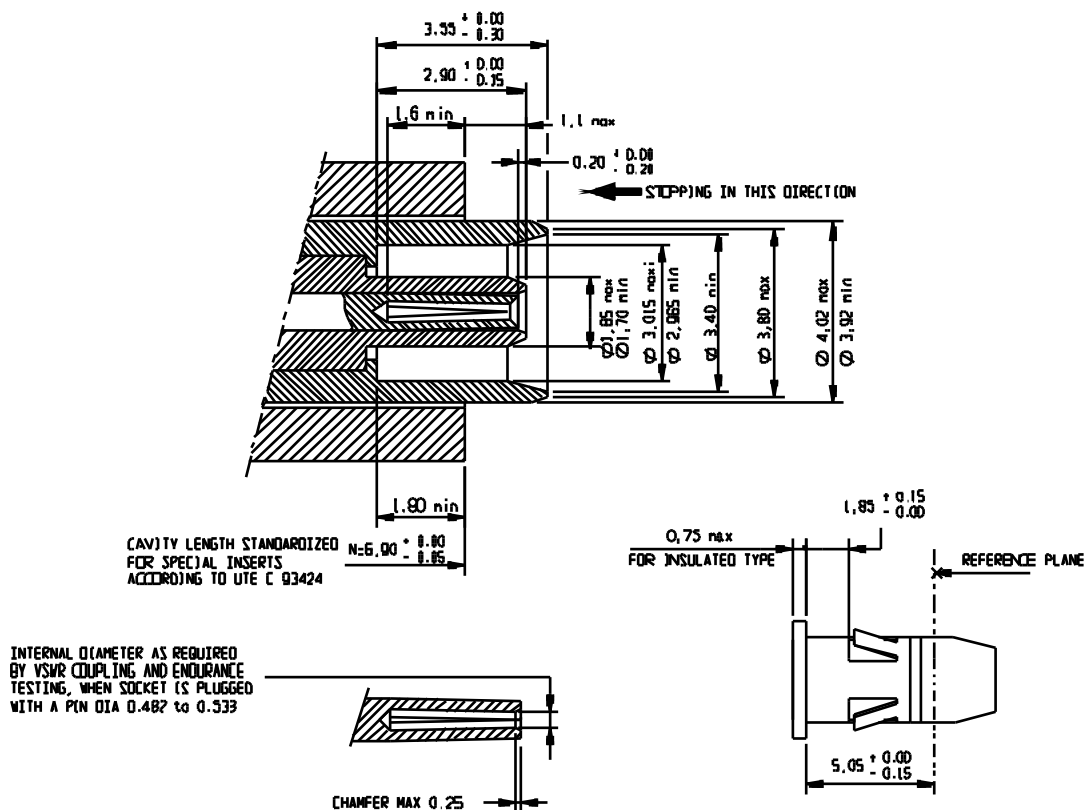

### MALE COAXIAL CONTACT

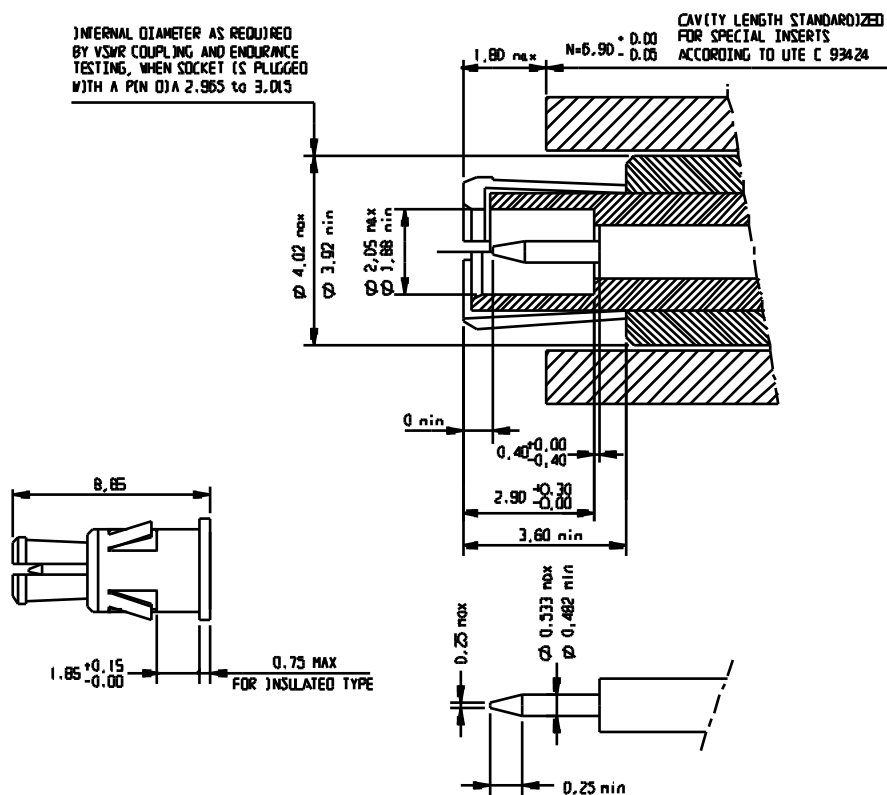

# MOUNTING DETAILS FOR COAXIAL CONTACTS

## MOUNTING DETAILS FOR COAXIAL CONTACTS SERIES KMX 3 RIGHT ANGLE TERMINATIONS

For information, see diagram IV.

- Strip the cable according to the connector style and take care not to damage the braid and cable core (diagram I).
- Fit the heat shrink sleeve \* HSS (diagram II).
- Tin the cable core.
- Push the cable into the body 2 until it is against the shoulder of the body (diagram III).
- Solder the cable core to the inner contact 5 (diagram III).
- Solder the screen \*\* of the cable to the connector body 2 (diagram III).
- Push insulator pad 3 and connector cap 4 into back of the connector body 1 (diagram III).
- Solder the connector cap to the connector body 1 (diagram III).
- Shrink sleeve over connector and cable (diagram III).

\* Excepted for semi-rigid cable.

\*\* For semi-rigid cable : solder the screen.

### STRIPPING

<p><b>KMX 3 - M 092 and F 092</b>  <b>KMX 3 - M 112 and F 112</b></p>	
<p><b>KMX 3 - M 142 and F 142</b></p>	
<p><b>KMX 3 - M 112 and F 112</b>  <b>E 756 C 57 - C 58 - C 59</b>  <b>C 60 - C 61 - C 62 - C 65 - C 66</b></p>	

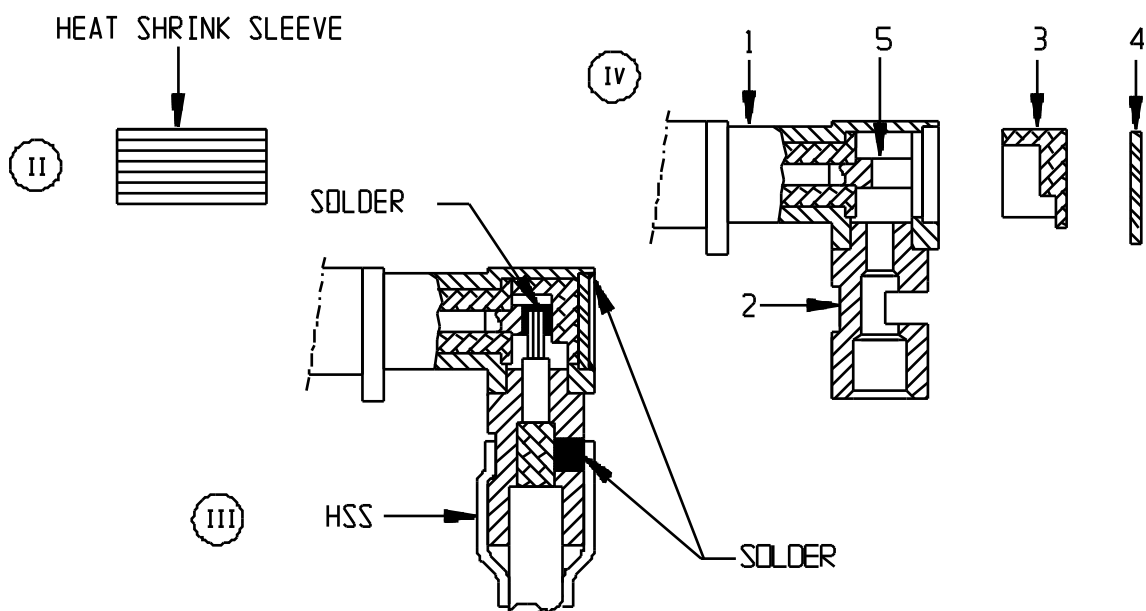

# SERIES HE 810

## MOUNTING DETAILS FOR COAXIAL CONTACTS

### MOUNTING DETAILS FOR COAXIAL CONTACTS SERIES KMX 3 STRAIGHT TERMINATIONS

For information, see diagram IV.

- Strip the cable according to the connector style and take care not to damage the braid and the cable core (diagram I).
- Fit the heat shrink sleeve \* HSS (diagram II).
- Tin the cable core.
- Fit the sleeve 4 and the insulating washer 3 (diagram III).
- Push the cable core into the inner contact 2 and solder, the solder should not contaminate the outside  $\varnothing$  of the inner contact 2 (diagram III).
- Push the cable into the back of the connector body 1 (diagram IV) until it against the shoulder of the body.
- Solder the screen of the cable \*\* and the sleeve to the connector body 1 (diagram V).
- Shrink sleeve \* over connector and cable.

\* Excepted for semi-rigid cable.

\*\* For semi-rigid cable : solder the screen.

### STRIPPING

<b>KMX 3 - M 101 and F 101</b> <b>E 756 C 15 and C 16</b>	
<b>E 756 C 11 and C 12</b>	
<b>KMX 3 - M 081 and F 081</b> <b>E 756 C 09 et C 10</b>	
<b>KMX 3 - M 131 and F 131</b>	

HEAT SHRINK SLEEVE

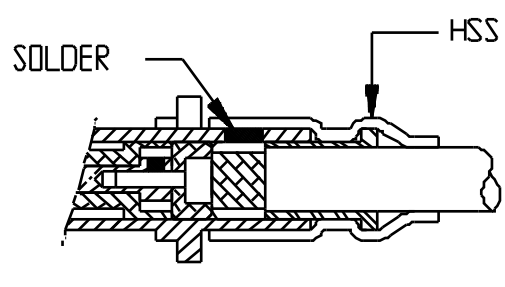
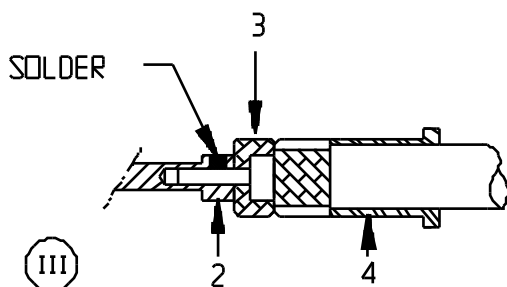
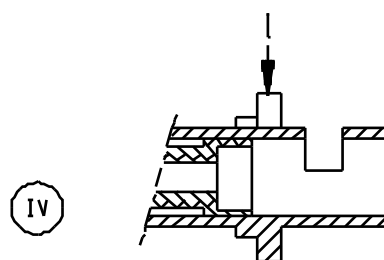
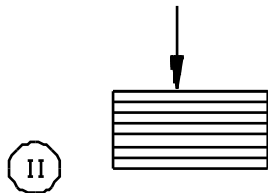



# SERIES HE 810 HIGH POWER CONTACTS

**KMX 3 series specification NFC 93569 - 10 A under 30 Vdc - 15 A peak**

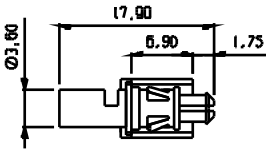
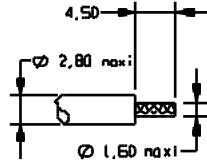
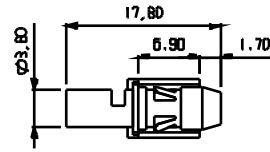
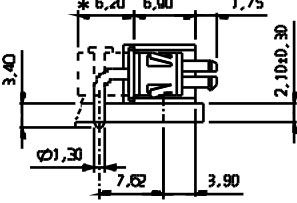
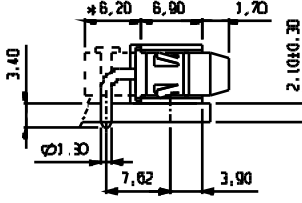
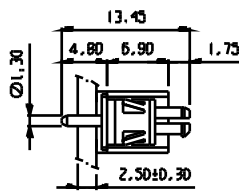
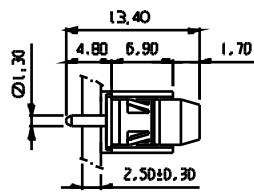
MALE		FEMALE
<p><b>KMX 3 - M 121</b></p> 	<p>Cable preparation</p>  <p>Solder termination</p>	<p><b>KMX 3 - F 121</b></p> 
<p><b>KMX 3 - M 132</b></p> 	<p>Male and female power contacts with 90 p.c.b. terminations.</p> <p>P.c.b. thickness <math>3,70 \pm 0,30</math></p> <p style="text-align: center;">← *E756 C25 E756 C26* →</p>	<p><b>KMX 3 - F 132</b></p> 
<p><b>KMX 3 - M 141</b></p> 	<p>Male and female power contacts with straight p.c.b. terminations.</p> <p>P.c.b. thickness <math>5 \pm 0,30</math></p> <p style="text-align: center;">← E756 C28 E756 C27 →</p>	<p><b>KMX 3 - F 141</b></p> 

\* Termination lengths according CEI recommendations.

## SPECIAL HIGH POWER CONTACTS 20 A under 30 VCC - 25 A peak

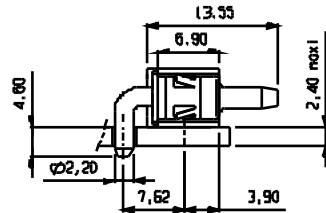
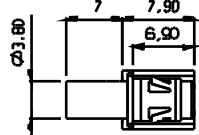
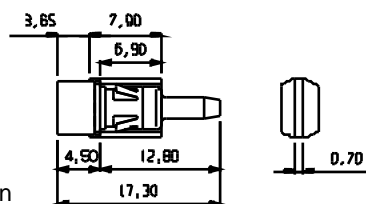
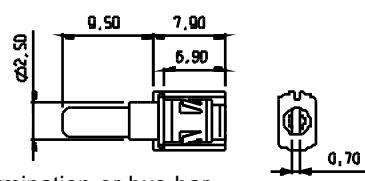
MALE	FEMALE
<p><b>M 134</b></p>  <p>Right angle termination</p>	<p><b>F 124</b></p>  <p>Crimping tool T and B : MS 3191 A.</p> <p>For wire AWG 12 to 14, positioner G12-G14.</p> <p>For wire AWG 16, positioner G16.</p> <p>Soldering or crimping termination</p>
<p><b>M 164</b></p>  <p>Straight termination for bus bar</p>	<p><b>F 164</b></p>  <p>Mother board termination or bus bar</p>

Others options, see Additional 97

# SERIES HE 810

## MOUNTING DETAILS FOR PRINTED CIRCUIT BOARD CONNECTOR WITH L.F. AND HIGH POWER CONTACTS

**RIGHT ANGLE MALE KMX 3 - M 132**  
**RIGHT ANGLE FEMALE KMX 3 - F 132**

**WITH RIGHT ANGLE MALE**  
**L.F. TERMINATIONS**

NOTE :

For other dimensions, see page 23 for the coaxial contacts mounting details.

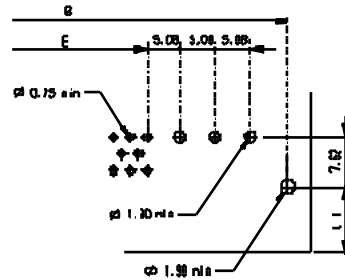

**RIGHT ANGLE MALE KMX 3 - M 132**  
**RIGHT ANGLE FEMALE KMX 3 - F 132**

**WITH RIGHT ANGLE FEMALE**  
**L.F. TERMINATIONS**

NOTE :

For other dimensions, see page 33 for the coaxial contacts mounting details.

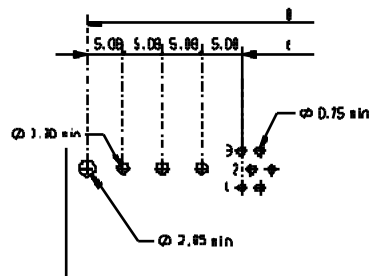

**RIGHT ANGLE MALE KMX 3 - M 141**  
**RIGHT ANGLE FEMALE KMX 3 - F 141**

**WITH STRAIGHT MALE AND FEMALE**  
**L.F. TERMINATIONS**

NOTE :

For other dimensions, see page 27 to 31 for the coaxial contacts mounting details.

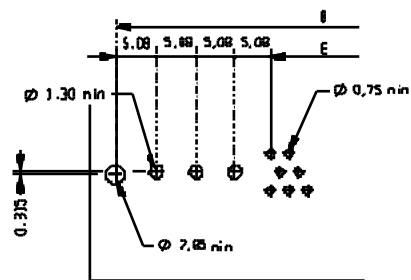

**RIGHT ANGLE KMX 3 - M 134**  
**(20 A)**

NOTE :

Mounting details are the same as the KMX 3 - M 132 and KMX 3 - F 132 except for drilling Ø 2.2.



ATI reserves the right to discontinue the manufacture or change specifications without prior notice, or any parts illustrated in this data sheet.  
For more information, please take advice.